

Getting Started with 5G Modem Card

User Guide

Version: 05

DocId: MV31_startup_guide_v05



User Guide:	Getting Started with 5G Modem Card
Version:	05
Date:	2021-03-31
DocId:	MV31_startup_guide_v05
Status	Public / Released

GENERAL NOTE

THIS DOCUMENT CONTAINS INFORMATION ON THALES PRODUCTS. THALES RESERVES THE RIGHT TO MAKE CHANGES TO THE PRODUCTS DESCRIBED HEREIN. THE SPECIFICATIONS IN THIS DOCUMENT ARE SUBJECT TO CHANGE AT THE DISCRETION OF THALES. THE PRODUCT AND THIS DOCUMENT ARE PROVIDED ON AN "AS IS" BASIS ONLY AND MAY CONTAIN DEFICIENCIES OR INADEQUACIES. THALES DOES NOT ASSUME ANY LIABILITY FOR INFORMATION PROVIDED IN THE DOCUMENT OR ARISING OUT OF THE APPLICATION OR USE OF ANY PRODUCT DESCRIBED HEREIN.

THALES GRANTS A NON-EXCLUSIVE RIGHT TO USE THE DOCUMENT. THE RECIPIENT SHALL NOT COPY, MODIFY, DISCLOSE OR REPRODUCE THE DOCUMENT EXCEPT AS SPECIFICALLY AUTHORIZED BY THALES.

Copyright © 2021, THALES DIS AIS Deutschland GmbH

Trademark Notice

Thales, the Thales logo, are trademarks and service marks of Thales and are registered in certain countries.
PCI-SIG®, PCIe® and the PCI Express® design mark are registered trademarks and/or service marks of PCI-SIG.
Microsoft and Windows are either registered trademarks or trademarks of Microsoft Corporation in the United States and/or other countries.

Contents

0	Document History	4
1	Introduction	5
1.1	Supported Products	5
1.2	Related Documents	5
2	Getting Started with 5G Modem Cards	6
2.1	Using USB Variant	6
2.1.1	Technical Requirements	6
2.1.2	Connecting MV31-W to the 5G Modem Card Adapter Board	6
2.2	Using PCIe® Variant	8
2.2.1	Technical Requirements	8
2.2.2	Connecting MV31-W to the 5G Modem Card Adapter Board	9
2.3	Start Up the Modem Card	10
2.3.1	Script based Driver Installation	10
2.3.2	Manual USB Driver Installation	11
2.3.3	Manual PCIe® Driver Installation	19
2.3.4	Enter SIM and go Online	26
2.3.5	Reading MV31-W Properties	28
3	Appendix	29
3.1	5G Modem Card Adapter Board	29
3.1.1	Package content USB Variant	29
3.1.2	Package content PCIe® M.2 Variant	29
3.2	5G Modem Card Adapter Board Description	30
3.2.1	USB Variant	32
3.2.2	PCIe® M.2 Variant	32
3.2.3	PCIe® Golden Finger (Edge Connector) Configuration	33
3.3	Resistor Matrix Configuration	33
3.4	Power Supply Configuration	37
3.5	Configuration Switches	37
3.6	Additional Connectors	38

0 Document History

Preceding document: "Getting Started with 5G Modem Card", Version 04

New document: "Getting Started with 5G Modem Card" Version 04

Chapter	What is new
4.1	Revised Ordering Numbers and supported bands in Table 15

Preceding document: "Getting Started with 5G Modem Card", Version 03

New document: "Getting Started with 5G Modem Card" Version 04

Chapter	What is new
3.1.2	Added Ordering Number for PCIe Starter Kit
3.3	Revised Figure 8 regarding R9918 and R9919

Preceding document: "Getting Started with 5G Modem Card", Version 02

New document: "Getting Started with 5G Modem Card" Version 03

Chapter	What is new
2.3.1	Added Chapter for script based driver installation

Preceding document: "Getting Started with 5G Modem Card", Version 01

New document: "Getting Started with 5G Modem Card" Version 02

Chapter	What is new
Throughout Document	Distinguish between USB and PCIe M.2 Variant of Starter Kit
2.3.3	Added Chapter for PCI Driver Installation
3	Revised whole chapter adding configuration description

New document: "Getting Started with 5G Modem Card" Version 01

Chapter	What is new
---	Initial document setup.

1 Introduction

This document describes a ready-to-use development and test environment for the Thales 5G Modem Card.

The development and test environment comprises the following hardware components

- 5G Modem Card MV31-W
- 5G Modem Card Adapter Board

The purpose of this document¹ is to guide you through the process of connecting the hardware, installing the supplied drivers on a Microsoft® Windows 10 system and getting started with 5G Modem Card.

1.1 Supported Products

This document applies to the following Thales 5G Modem cards:

- Cinterion® MV31-W sub6 USB
- Cinterion® MV31-W mmWave USB
- Cinterion® MV31-W sub6 PCIe®
- Cinterion® MV31-W mmWave PCIe

5G Modem Card in this document refers to all of the above mentioned product variants. Where necessary a note is made to differentiate between these product variants.

1.2 Related Documents

[1] MV31-W Hardware Interface Description

¹ The document is effective only if listed in the appropriate Release Notes as part of the technical documentation delivered with your Thales module.

2 Getting Started with 5G Modem Cards

2.1 Using USB Variant

2.1.1 Technical Requirements

- MV31-W sub6 USB (for details see [Figure 1](#) and [\[1\]](#))²
- corresponding driver package (USB)
- Computer running Windows 10, USB 3.0 Interface
- Local administrator privileges on the particular Windows computer to install and uninstall the drivers
- 5G Modem Card Adapter Board USB Variant (for details see [Section 3.1](#))
- Accessories for sub6G USB variant of MV31-W:
 - Four short 50 Ohms RF adapter cables with MHF4 type connectors to connect the appropriate MHF4 type connectors on the 5G Modem Card Adapter Board (supplied by Thales)
 - Four external 50 Ohms RF antennas with SMA connector to connect the SMA connector on the 5G Modem Card Adapter Board (supplied by Thales)
 - USB 3.0 cable (supplied by Thales)
- Appropriate application for controlling the module from within a PC's operating system. For Windows, e.g. Windows Hyperterminal
- (U)SIM from a UMTS/LTE/NR network provider

2.1.2 Connecting MV31-W to the 5G Modem Card Adapter Board

To properly connect the 5G Modem Card and all accessories to the 5G Modem Card Adapter Board please complete the steps listed below. The complete setup with the 5G Modem Card mounted onto the 5G Modem Card Adapter Board is shown in [Figure 2](#).

- Ensure that all jumpers and switches on the 5G Modem Card Adapter Board are set to their positions as shown in [Table 10](#) and [Table 11](#) and switch USB/PCIe is in position USB (on).
- Place Thermo Pad with the self adhesive side (remove protection foil) on the 5G Modem Card Adapter Board close to the M.2 connector.
- Insert the 5G Modem Card into the M.2 connector on the 5G Modem Card Adapter Board and insert the screw to keep the 5G Modem Card in position and connected.
- Connect the MHF4 type connectors for the antennas on the 5G Modem Card Adapter Board (ANT0, ANT1, ANT2, ANT3) to the matching MHF4 type connectors on the 5G Modem Card.
- Screw the external antennas to the appropriate SMA connectors on the 5G Modem Card Adapter Board (ANT0, ANT1, ANT2, ANT3).
- Insert the (U)SIM card into the card reader for 1st SIM.
- Plug the USB 3.0 USB cable to the USB jack at the 5G Modem Card Adapter Board.

After connecting the 5G Modem Card with the 5G Modem Card Adapter Board, the 5G Modem Card can be switched on by connecting the other end of the USB cable to the PC. The initial startup and possible USB driver installation are described in [Section 2.3](#).

² For ordering information see [\[1\]](#).

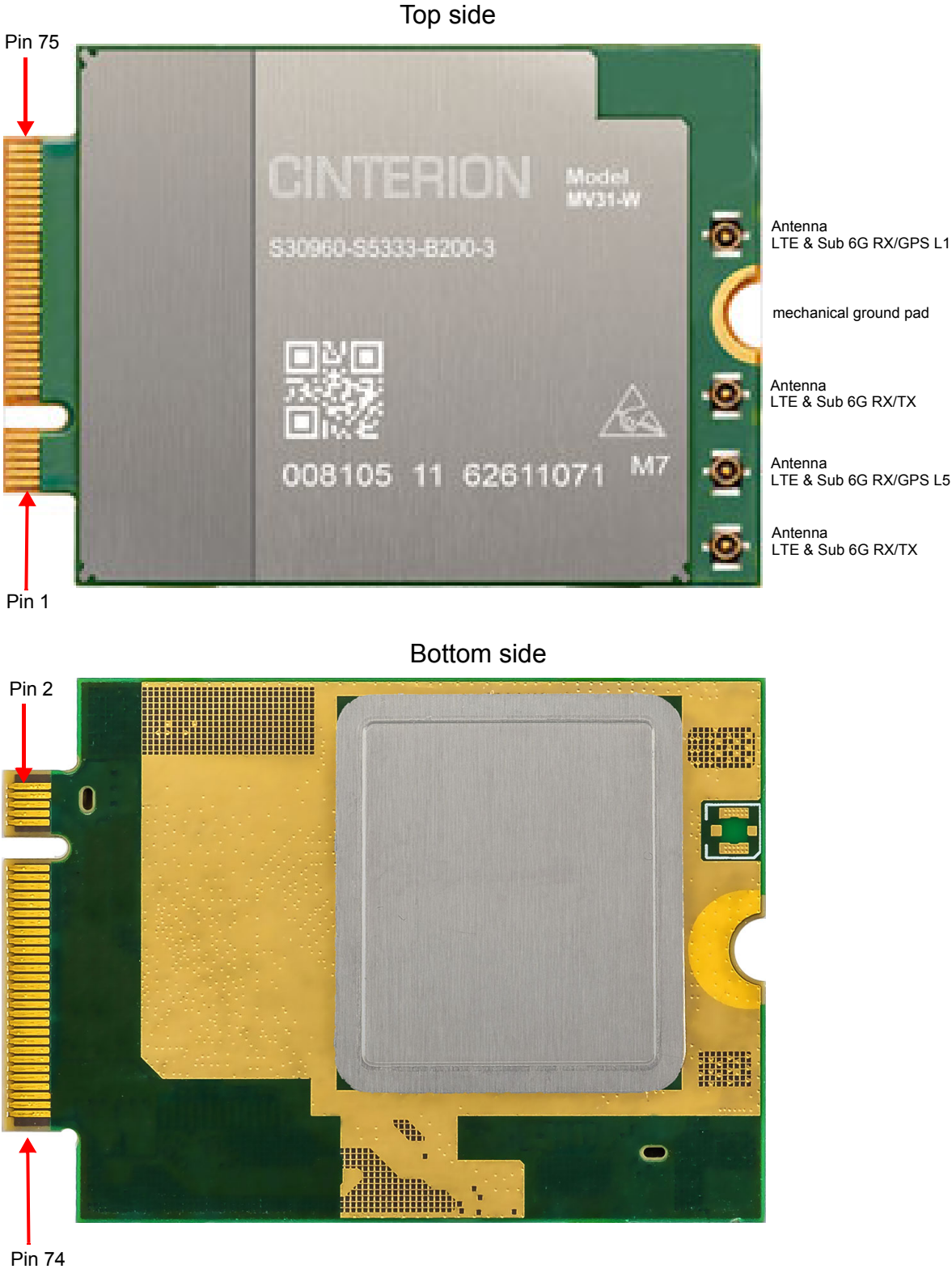

Figure 1: 5G Modem Card



Figure 2: MV31-W mounted on 5G Modem Card Adapter Board

2.2 Using PCIe® Variant

2.2.1 Technical Requirements

- MV31-W sub6 PCIe (for details see [Figure 1](#) and [\[1\]](#))³
- corresponding driver package (PCIe)
- Computer running Windows 10, PCIe M.2 Interface
- Local administrator privileges on the particular Windows computer to install and uninstall the drivers
- 5G Modem Card Adapter Board PCIe Variant (for details see [Section 3.1](#))
- Accessories for sub6G PCIe variant of MV31-W:
 - Four short 50 Ohms RF adapter cables with MHF4 type connectors to connect the appropriate MHF4 type connectors on the 5G Modem Card Adapter Board (supplied by Thales)
 - Four external 50 Ohms RF antennas with SMA connector to connect the SMA connector on the 5G Modem Card Adapter Board (supplied by Thales)
 - FFC cable with M.2 Adapter Card
- Appropriate application for controlling the module from within a PC's operating system. For Windows, e.g. Windows Hyperterminal
- (U)SIM from a UMTS/LTE/NR network provider

³. For ordering information see [\[1\]](#).

2.2.2 Connecting MV31-W to the 5G Modem Card Adapter Board

To properly connect the 5G Modem Card and all accessories to the 5G Modem Card Adapter Board please complete the steps listed below. The complete setup with the 5G Modem Card mounted onto the 5G Modem Card Adapter Board is shown in [Figure 3](#).

- Ensure that all jumpers and switches on the 5G Modem Card Adapter Board are set to their positions as shown in [Table 10](#) and [Table 11](#) and switch USB/PCIe is in position PCIe (off).
- Place Thermo Pad with the self adhesive side (remove protection foil) on the 5G Modem Card Adapter Board close to the M.2 connector.
- Insert the 5G Modem Card into the M.2 connector on the 5G Modem Card Adapter Board and insert the screw to keep the 5G Modem Card in position and connected.
- Connect the MHF4 type connectors for the antennas on the 5G Modem Card Adapter Board (ANT0, ANT1, ANT2, ANT3) to the matching MHF4 type connectors on the 5G Modem Card.
- Screw the external antennas to the appropriate SMA connectors on the 5G Modem Card Adapter Board (ANT0, ANT1, ANT2, ANT3).
- Insert the (U)SIM card into the card reader on your host device.
- Connect FFC cable on one side to the FFC connector on the 5G Modem Card Adapter Board and the other side to the M.2 Adapter Card.
- Plug the M.2 Adapter Card into your PC

After connecting the 5G Modem Card with the 5G Modem Card Adapter Board, the 5G Modem Card can be switched on by switching on your PC. The initial startup and possible PCIe driver installation are described in [Section 2.3](#).

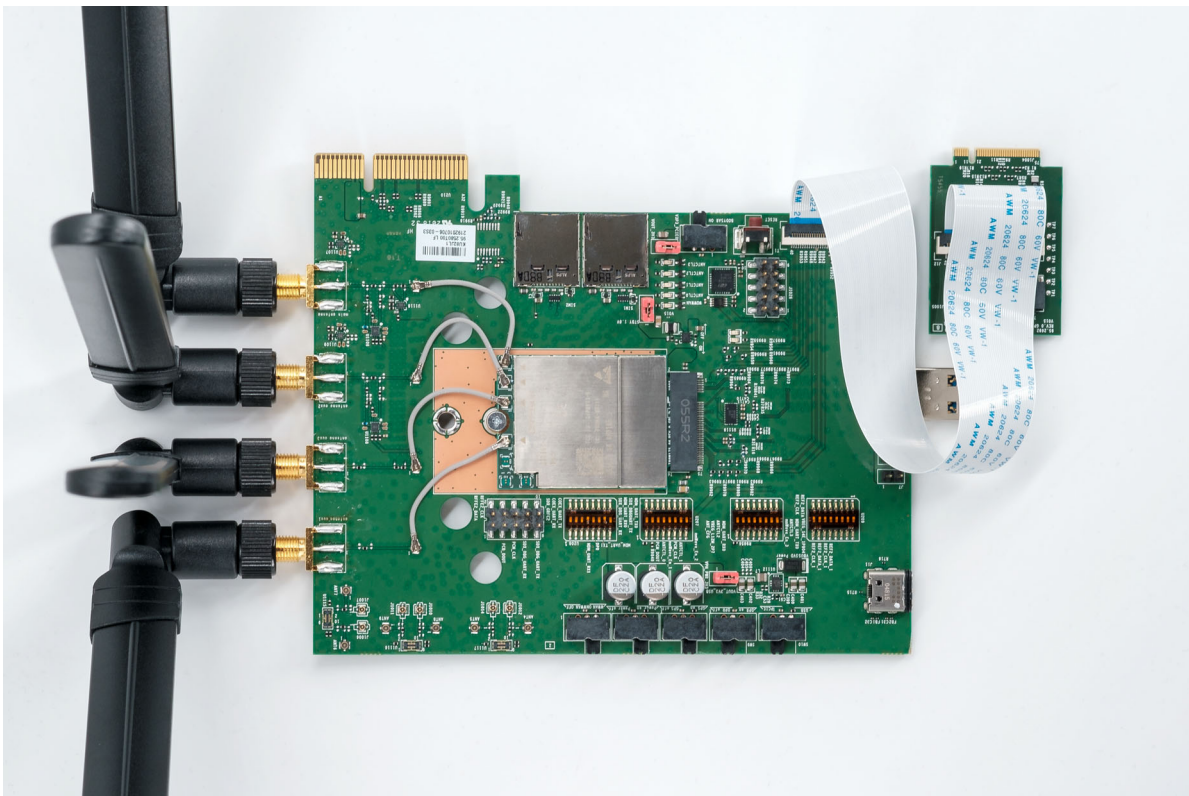

Figure 3: 5G Modem Card Adapter Board with PCIe M.2 Interface

2.3 Start Up the Modem Card

After connecting the 5G Modem Card to the 5G Modem Card Adapter Board as described in [Section 2.1.2](#), the 5G Modem can be used.

Note: The driver package provided by Thales needs to be available. Extract and Copy the supplied driver files to a folder on the Windows computer. Be sure to use the latest driver software supplied by Thales.

The driver package depends on the interface of the MV31-W Variant (USB or PCIe) and contains all the drivers needed for this variant MV31-W (see [Table 1](#)).

Table 1: Driver Package Content

Driver	Installation sequence	Starter Kit connected via USB3.0		MV31-W connected via PCIe M.2 or PCIe Edge Connector	
			Directory		Directory
MHI	1	not required	-	required	\\MHI
UDE	2	not required	-	required	\\UDE
QUD	3	required	\\QUD_GNSS	required	\\QUD_GNSS
GNSS	4	required	\\QUD_GNSS	required	\\QUD_GNSS

2.3.1 Script based Driver Installation

The drivers can be installed by a script. Therefore connect the Starter Kit with your PC first. Then run as "Administrator" the file "install_Thales.cmd", which is provided with the driver package. When unpacking the driver package, don't use space character in the folder path.

After running the script the interfaces shown in [Table 2](#) for USB or [Table 3](#) for PCIe should be installed.

2.3 Start Up the Modem Card

2.3.2 Manual USB Driver Installation

1. Start the Windows PC.
2. Open the Device Manager and select "View" and then "Device by connections".

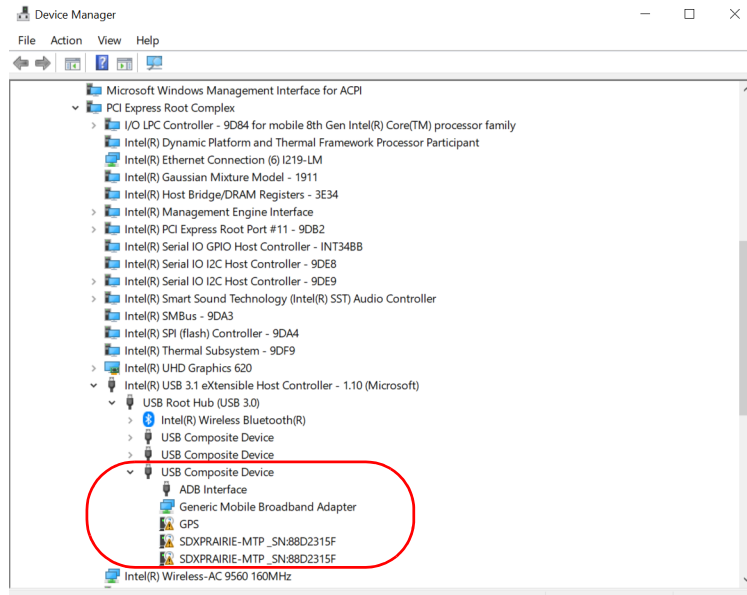

The "Generic Mobile Broadband Adapter" and "ADB Interface" are installed automatically by Windows 10.

3. For installing the drivers for both device "SDXPRAIRIE:MTP_SN88D231SF", select one of these devices and select from context menu "Update Driver Software".

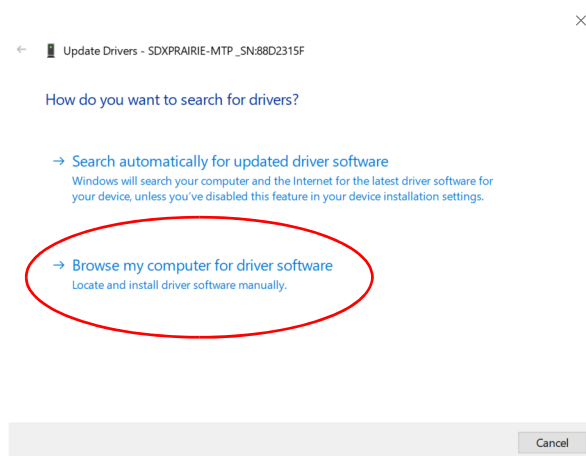

4. Select "Browse my computer for driver software"

2.3 Start Up the Modem Card

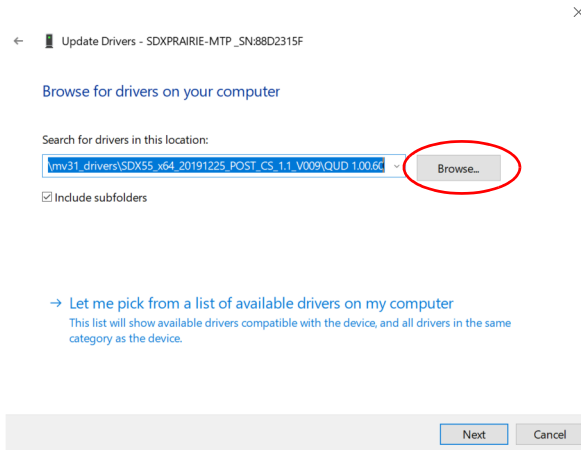

5. Push button "Browse"

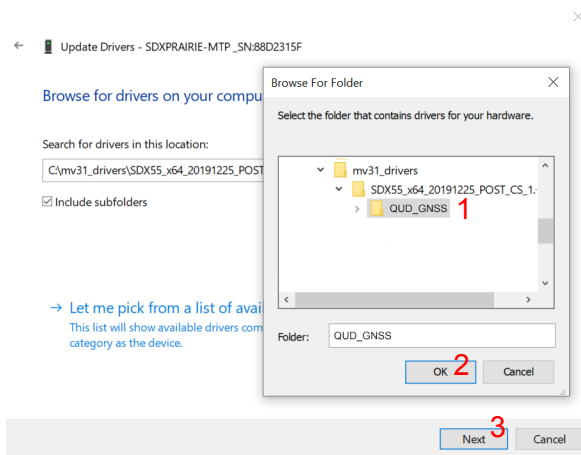

6. Go to the directory of the QUD driver (1), push button "OK" (2) and then push button "Next" (3).

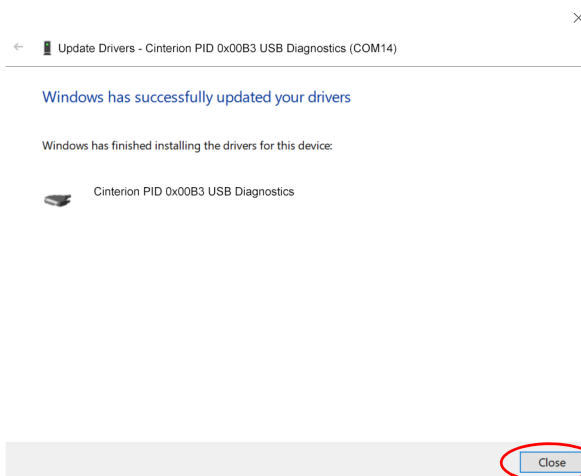

7. Driver for "Diagnostic Port" is successfully installed under "Ports (COM & LPT)" and then push button "Close" to finish the installation process. With driver version 005 or newer the "NMEA port" will be installed in parallel to the "Diagnostic Port".

2.3 Start Up the Modem Card

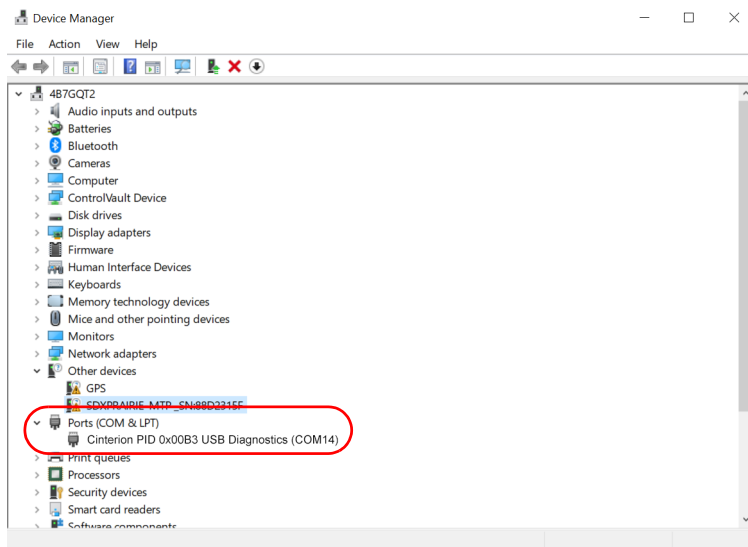

8. To install the second device "SDXPRAIRIE:MTP_SN88D231SF", repeat the steps 3 to 6

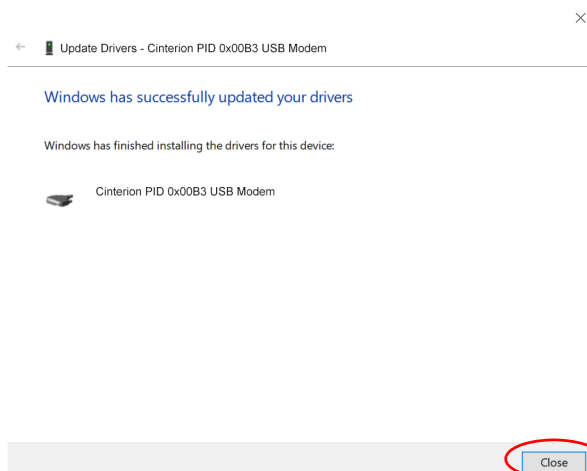

9. Driver for "Modem Port" is successfully installed under "Modems" and then push button "Close" to finish the installation process.

2.3 Start Up the Modem Card

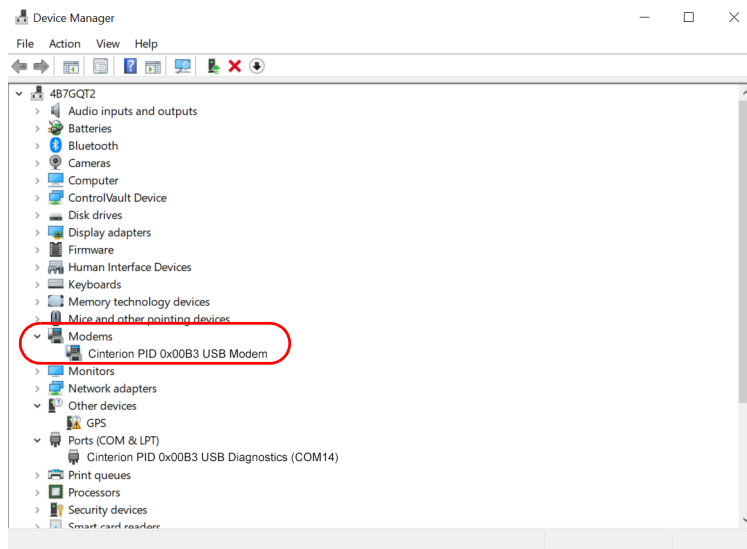

10. Select the remaining device GPS and select from context menu "Update Driver Software".

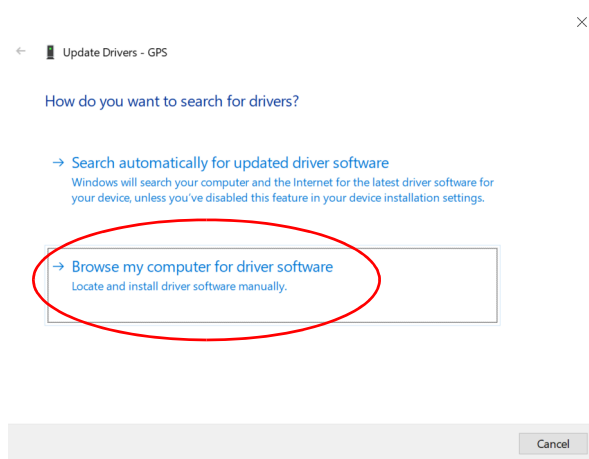

11. Select "Browse my computer for driver software"

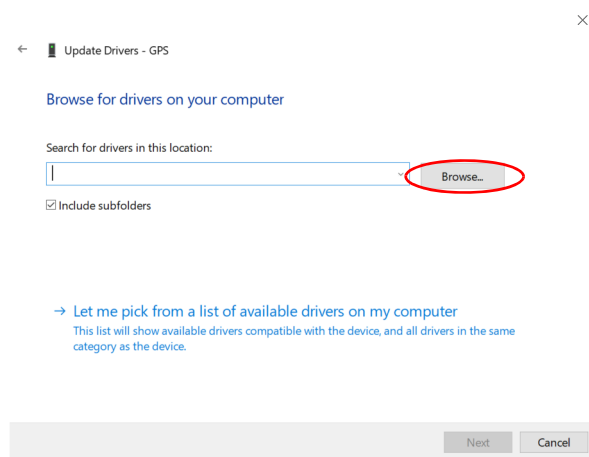

12. Push button "Browse"

2.3 Start Up the Modem Card

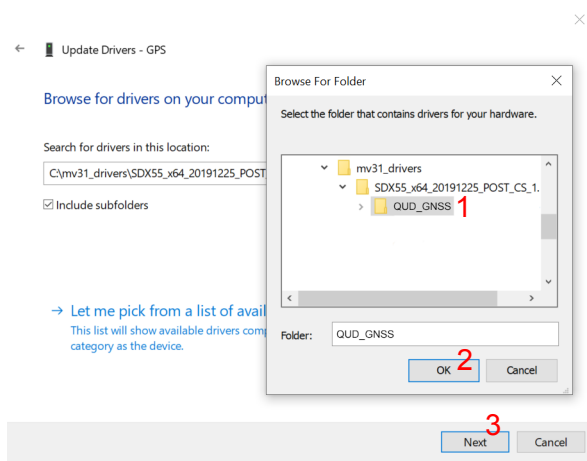

13. Go to the directory of the GNSS driver (1) and push button "OK" (2) and then push button "Next" (3).

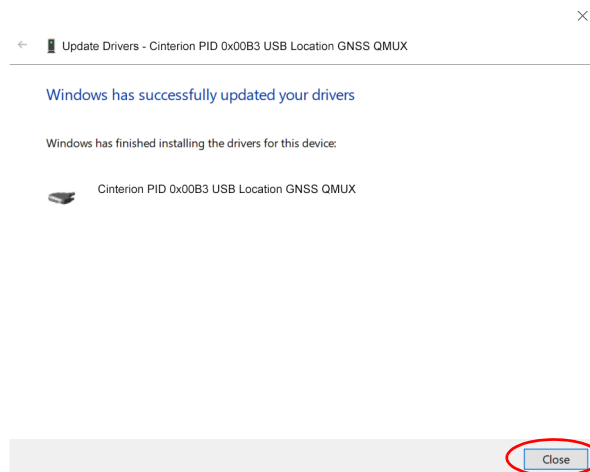

14. Driver for "GNSS QMUX" is successfully installed and then push button "Close" to finish the installation process.

2.3 Start Up the Modem Card

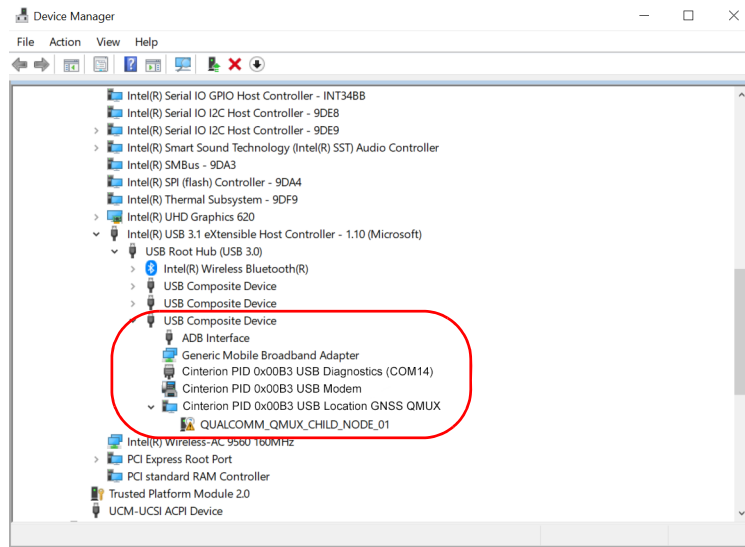

15. Select the device "QUALCOMM_QMUX_CHLD_NODE_01" and select from context menu "Update Driver Software".

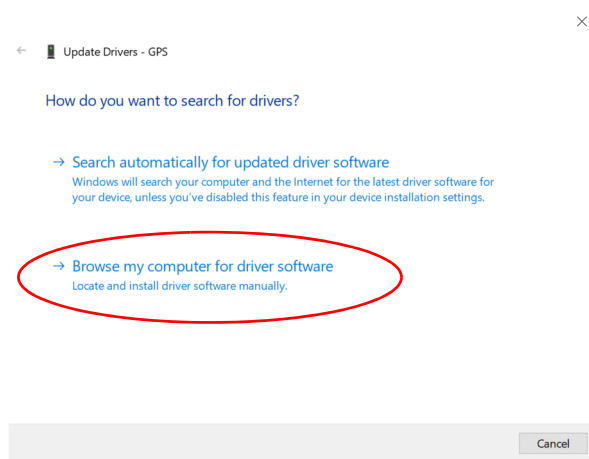

16. Select "Browse my computer for driver software"

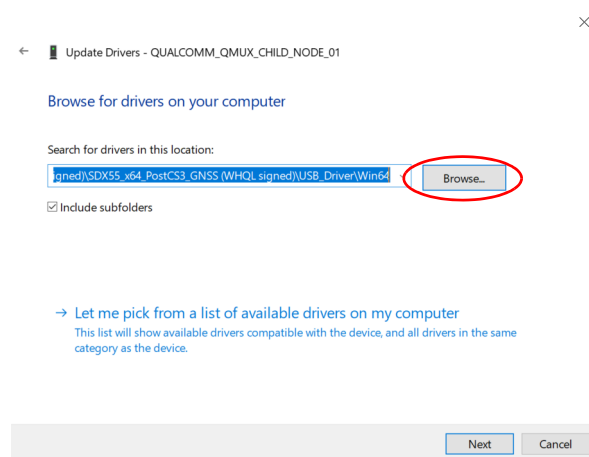

2.3 Start Up the Modem Card

17. Push button "Browse".

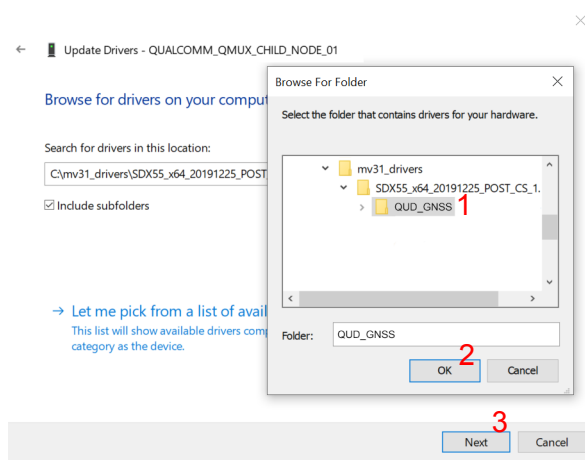

18. Go to the directory of the GNSS driver (1) and push button "OK" (2) and then push button "Next" (3).

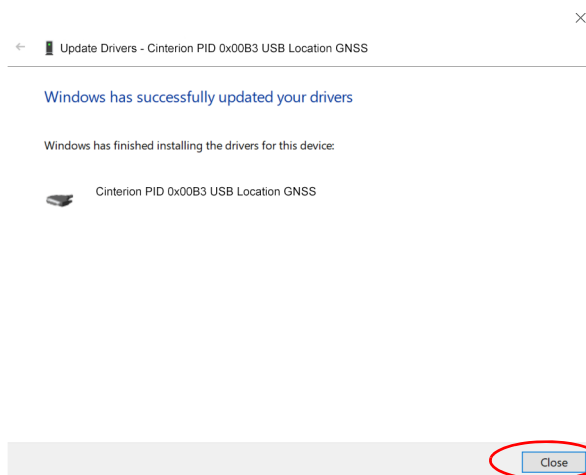

19. Driver for "Location GNSS" is successfully installed and then push button "Close" to finish the installation process.

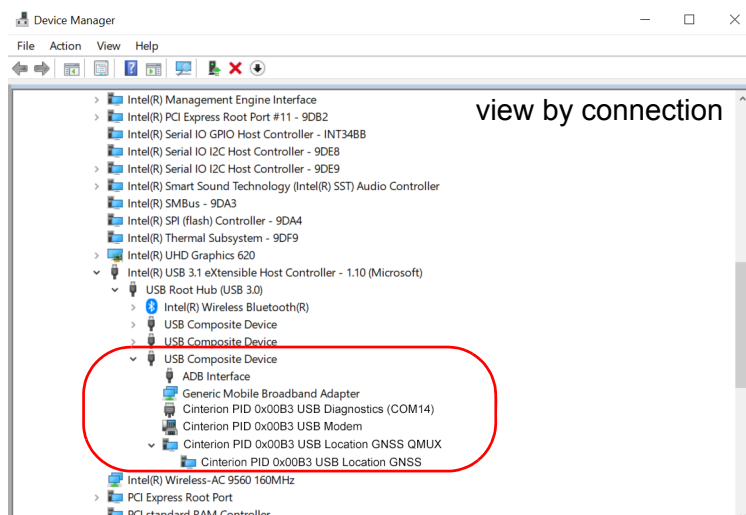

2.3 Start Up the Modem Card

After successful driver installation the installed devices are listed in the Windows Device Manager (see [Table 2](#)).

Table 2: Installed Interfaces for USB

Interface	Device Type
Generic Mobile Broadband Adapter	Network adapters
Cinterion PID 0x00B3 USB Modem	Modems
Cinterion PID 0x00B3 USB Diagnostics (COM14) ¹	Ports (COM & LPT)
Cinterion PID 0x00B3 USB NMEA (COM15) ^{1,2}	Ports (COM & LPT)
Cinterion PID 0x00B3 USB Location GNSS QMUX	System devices
Cinterion PID 0x00B3 USB Location GNSS	System devices
ADB Interface	Universal Serial Bus Devices

¹. COM Port number depends on the Host configuration

². NMEA available with USB driver version 005 or newer

2.3 Start Up the Modem Card

2.3.3 Manual PCIe® Driver Installation

1. Start the Windows PC.
2. Open the Device Manager and select "View" and then "Device by connections".

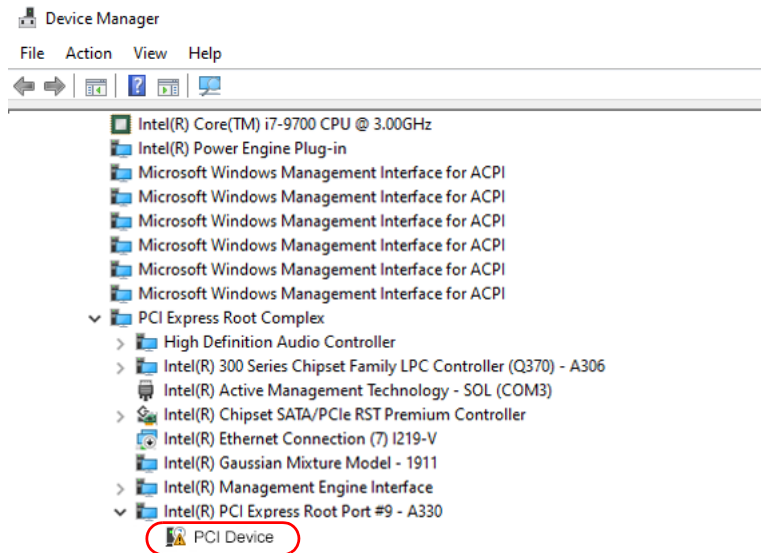

3. For installing the driver for the PCI Device, select this device and select from context menu "Update Driver Software".

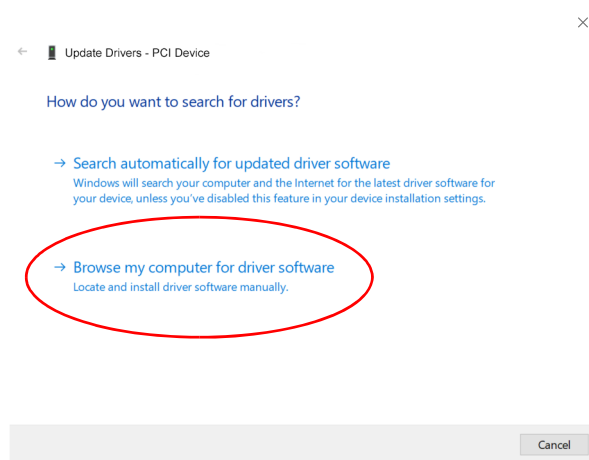

2.3 Start Up the Modem Card

4. Select "Browse my computer for driver software"

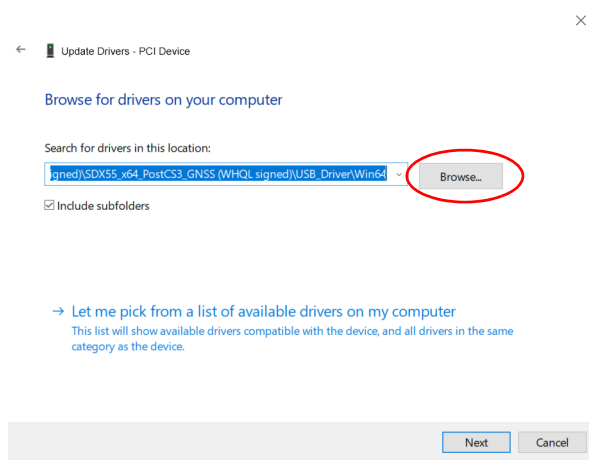

5. Push button "Browse"

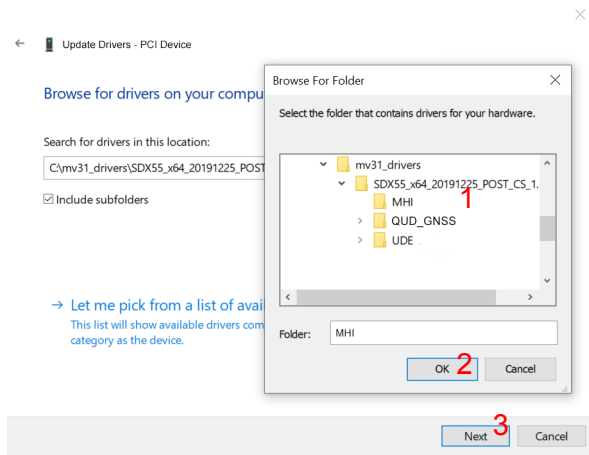

6. Go to the directory of the MHI driver (1), push button "OK" (2) and then push button "Next" (3).

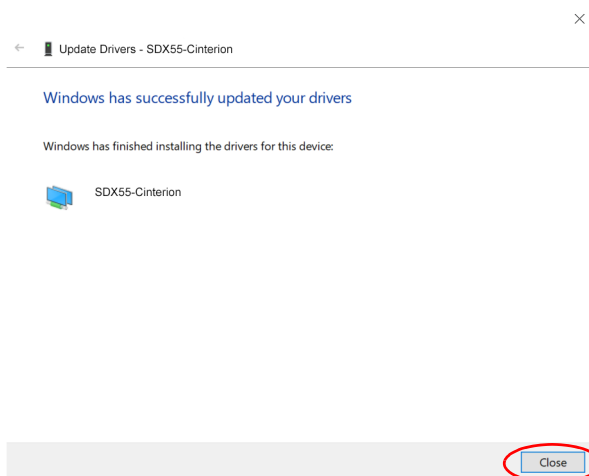

2.3 Start Up the Modem Card

- 7. MHI Driver for "PCI Device" is successfully installed under "PCI Express Root Port" and then push button "Close" to finish the installation process.

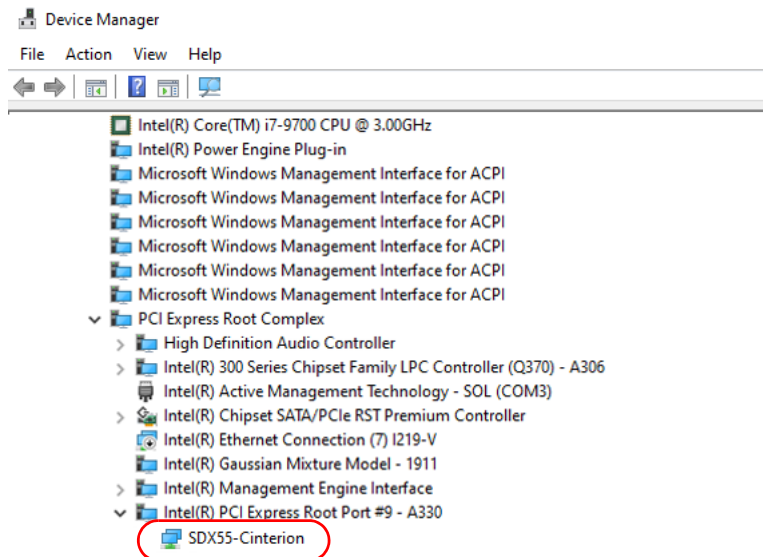

- 8. For installing the UDE driver, select "SDX55-Cinterion" and select from context menu "Update Driver Software" and afterwards select "Browse my computer for driver software".

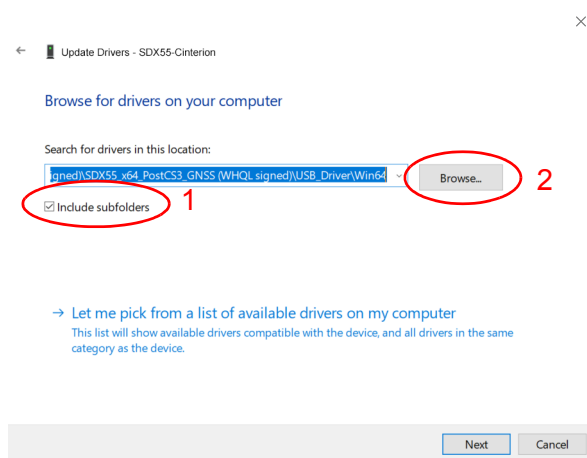

2.3 Start Up the Modem Card

9. Select check box "include subfolders" (1) and push button "Browse" (2).

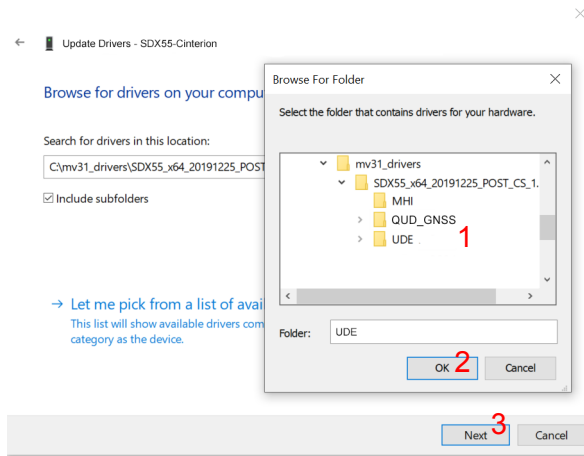

10. Go to the directory of the UDE driver (1), push button "OK" (2) and then push button "Next" (3).

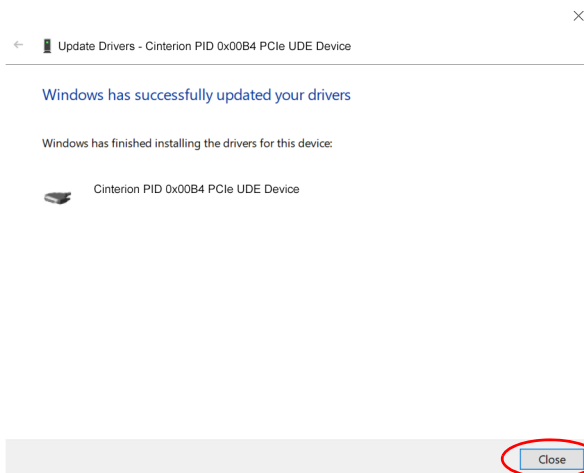

11. UDE Drivers are successfully installed under "SDX55-Cinterion" and then push button "Close" to finish the installation process.

2.3 Start Up the Modem Card

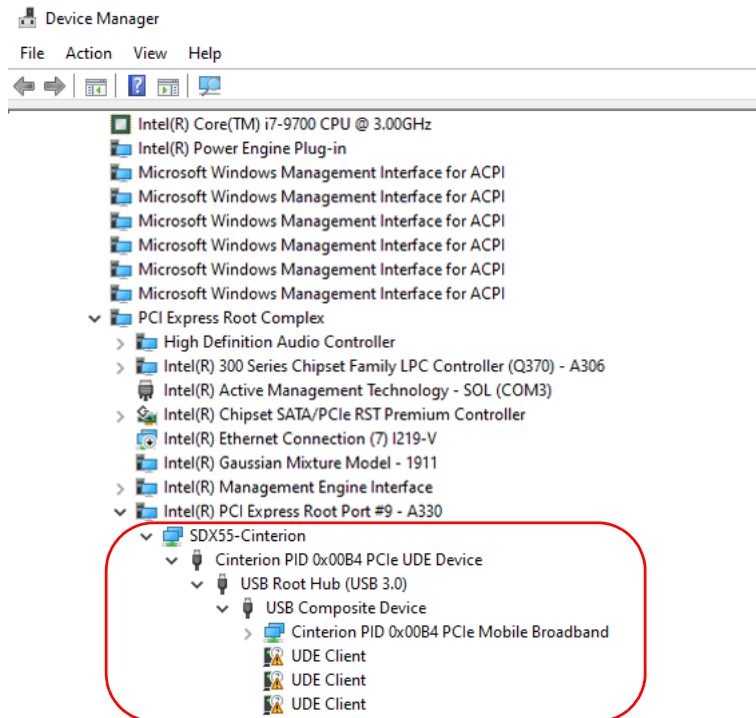

12. The following steps 13 to 17 have to be repeated for each UDE Client to get the Interfaces

- Cinterion PID 0x00B4 PCIe Modem
- Cinterion PID 0x00B4 PCIe Diagnostics
- Cinterion PID 0x00B4 PCIe Location GNSS QMUX

13. For installing the driver for the "UDE Client", select this device and select from context menu "Update Driver Software".

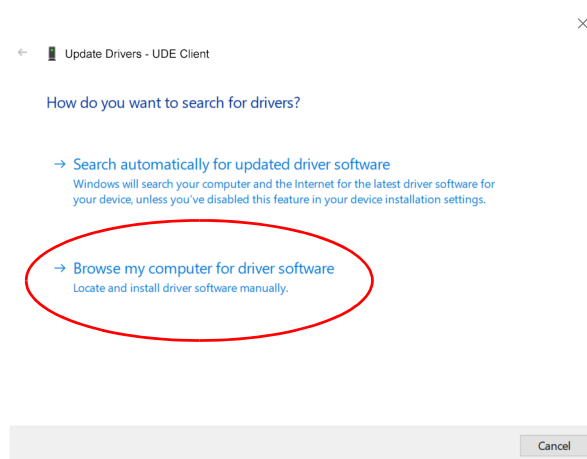

2.3 Start Up the Modem Card

14. Select "Browse my computer for driver software"

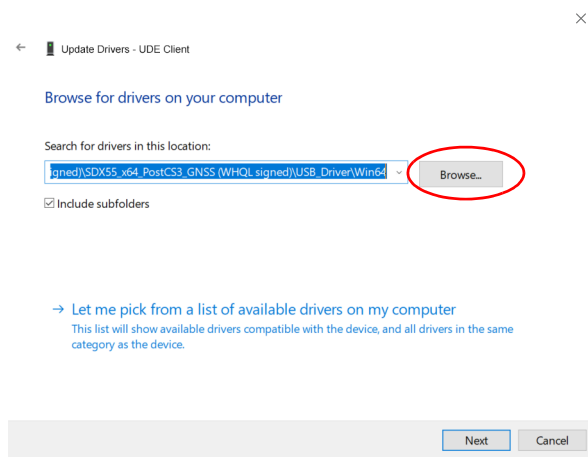

15. Push button "Browse"

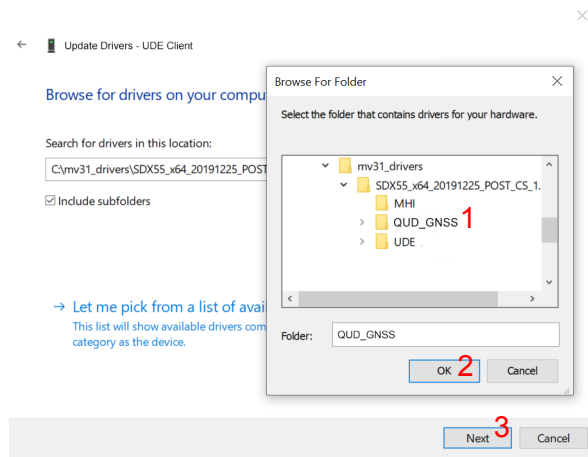

16. Go to the directory of the QUC_GNSS driver (1), push button "OK" (2) and then push button "Next" (3).

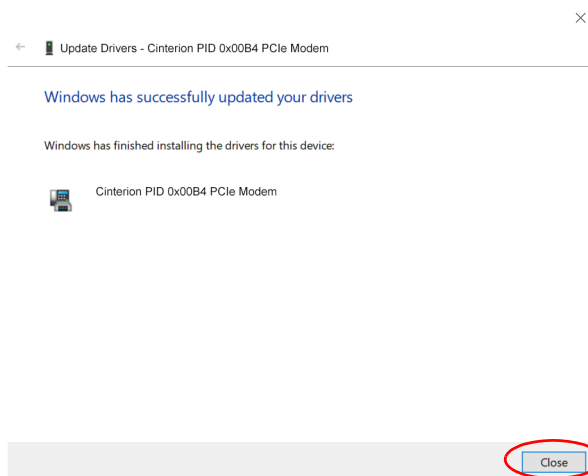

2.3 Start Up the Modem Card

17. The device for "UDE Client" is successfully installed and then push button "Close" to finish the installation process.
18. With the installation of all UDE Clients you will a new unknown device below "Cinterion PID 0x00B4 PCIe Location GNSS". Follow the steps 13 to 17 again for this device to install the last device "Cinterion PID 0x00B4 PCIe Location GNSS".

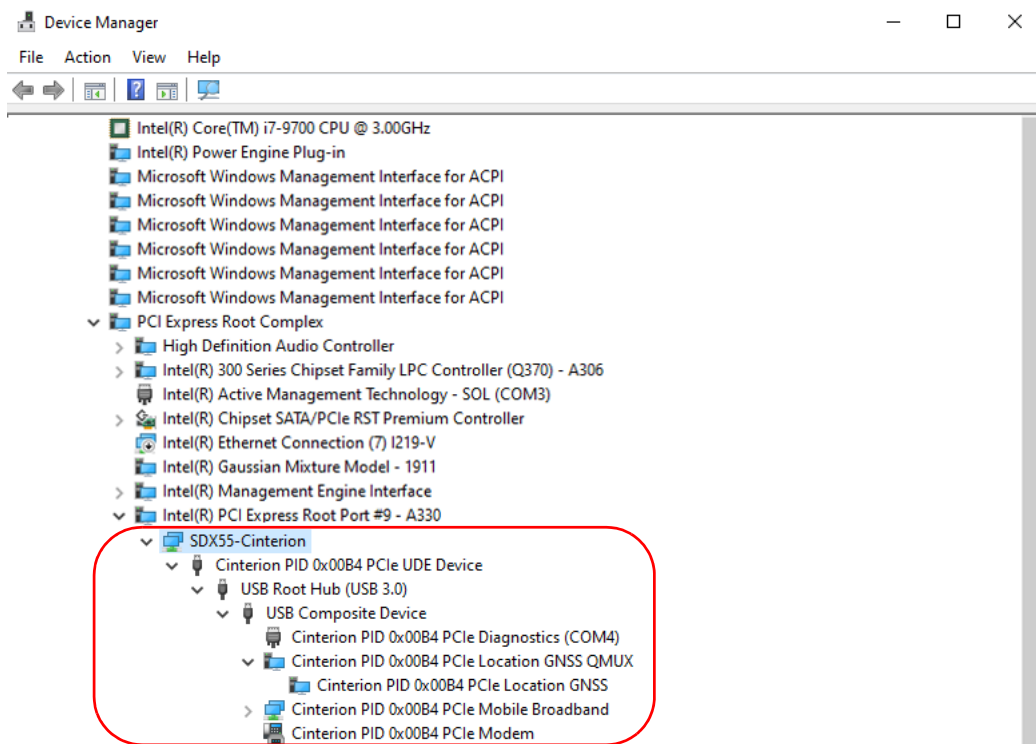

After successful driver installation the installed devices are listed in the Windows Device Manager (see [Table 3](#)).

Table 3: Installed Interfaces for PCIe

Interface	Device Type
SDX55 Cinterion	Qualcomm Modem Host Interface
Cinterion PID 0x00B4 PCIe UDE Device	USB
Generic Mobile Broadband Adapter	Network adapters
Cinterion PID 0x00B4 PCIe Mobile Broadband	Network adapters
Cinterion PID 0x00B4 PCIe Modem	Modems
Cinterion PID 0x00B4 PCIe Diagnostics (COM14) ¹	Ports (COM & LPT)
Cinterion PID 0x00B4 PCIe Location GNSS QMUX	System devices
Cinterion PID 0x00B4 PCIe Location GNSS	System devices

¹. COM Port number depends on the Host configuration

2.3 Start Up the Modem Card

2.3.4 Enter SIM and go Online

The following steps will show how to enter the SIM PIN for going Online with MV31-W:

1. When the used SIM is locked by a PIN, Windows 10 will inform you, that the PIN is required. Click on this message or go to "Network Connections" (Click on "Start" with left mouse button and select "Network connection", "Cellular" (1) and then "Unlock SIM" (2).

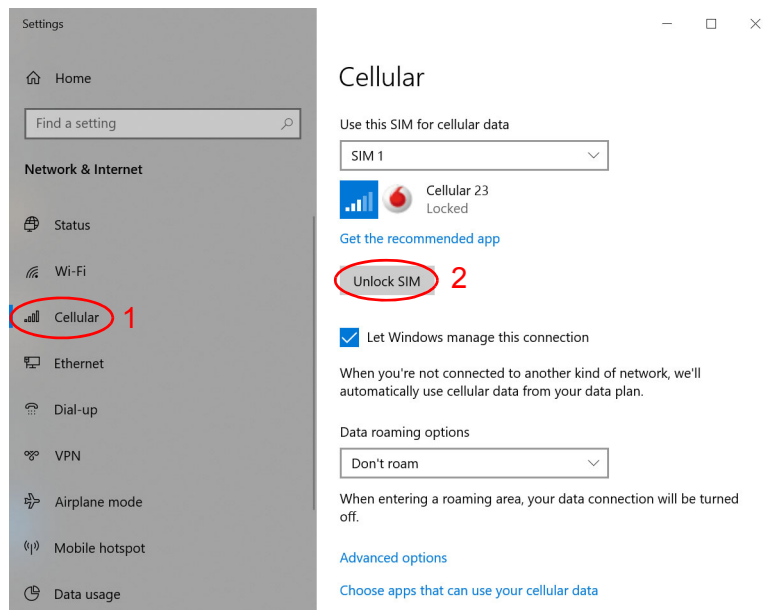

2. Enter your PIN

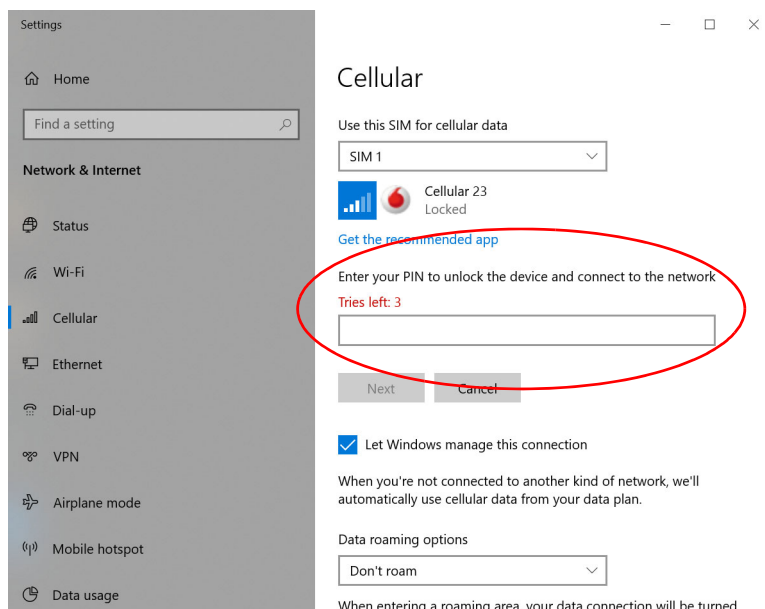

2.3 Start Up the Modem Card

3. After entering the PIN press button "Next"

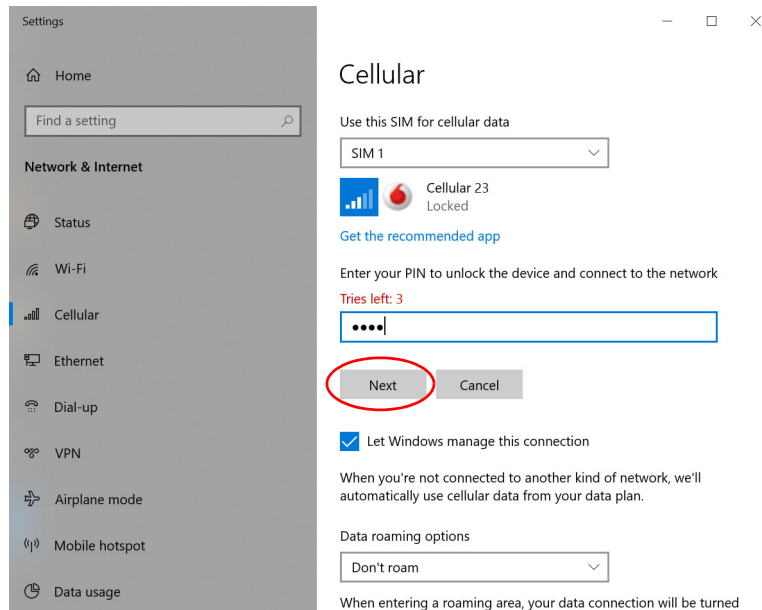

4. After successful registration to the network Windows 10 will show "Connected"

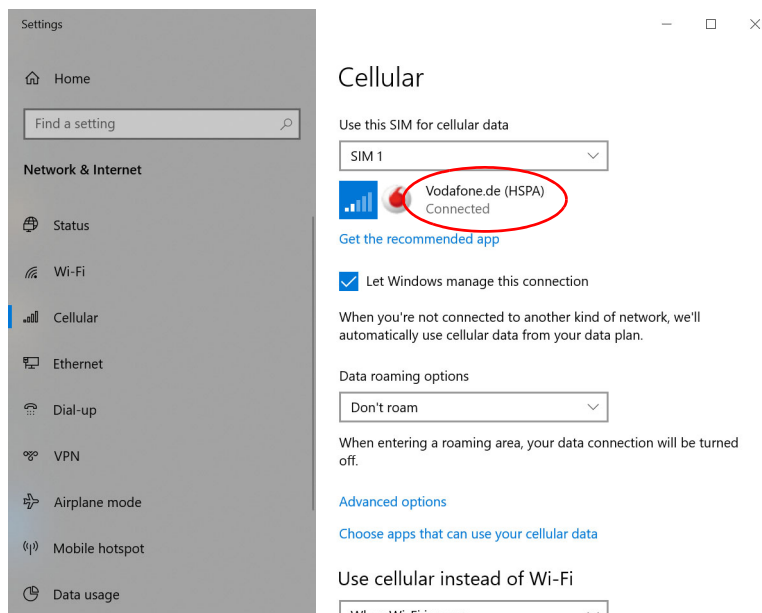

Now you can open a Internet Browser and go Online.

2.3 Start Up the Modem Card

2.3.5 Reading MV31-W Properties

To read the properties (Firmware version, IMEI, ...) of MV31-W go to "Network Connections" (Click on "Start" with left mouse button and select "Network connection" and then, "Cellular" (1). Under "Advanced Option" (2) the firmware version of the MV31-W will be shown.

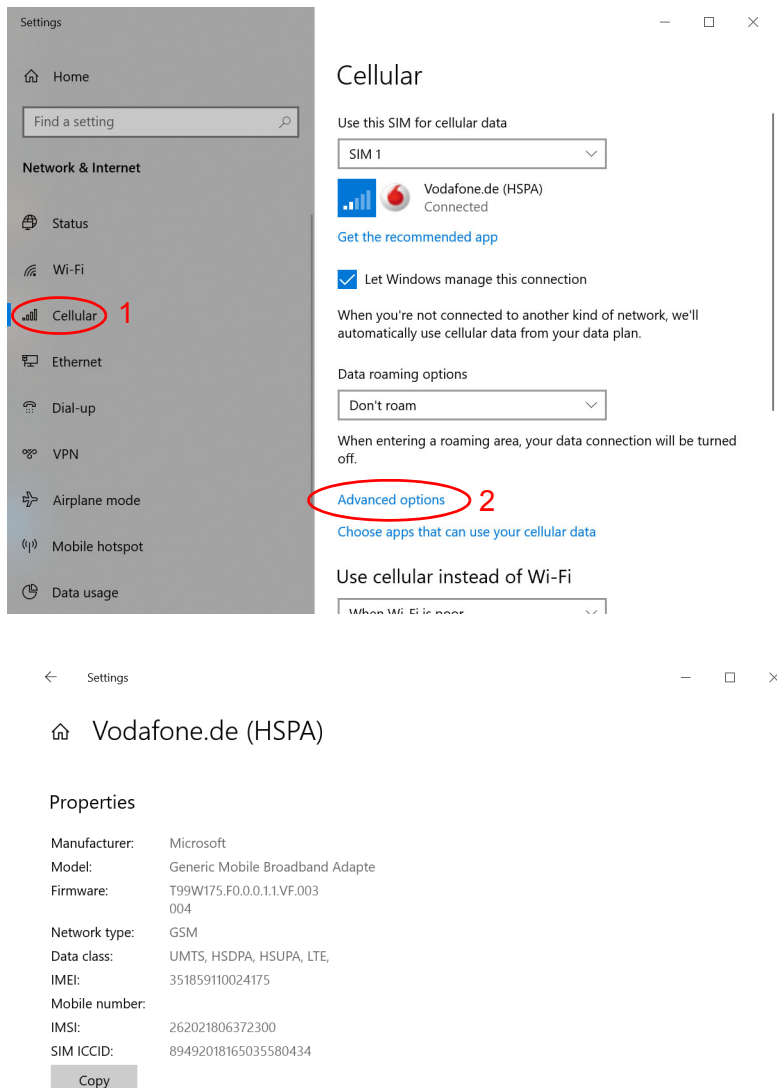

Additionally "Metered Connection", "APN settings" can be configured and the SIM PIN can be changed or removed too.

3 Appendix

3.1 5G Modem Card Adapter Board

3.1.1 Package content USB Variant

The 5G Modem Card Adapter Board (Figure 4 A) will be delivered together with

- 1 USB 3.0 cable (Figure 4 B)
- 1 USB cable with USB-C connector (Figure 4 C)
- 4 MHF4 type antenna cables (Figure 4 D)
- 4 UMTS/LTE/NR antennas (Figure 4 E)
- 1 Thermal Pad (Figure 4 F)
- 1 Screw to fix M.2 Card (Figure 4 G)
- 4 MHF4 to SMA antenna cables including washers and nuts (Figure 4 H)

GNSS Antenna and Power supply are not part of the 5G Modem Card Adapter Board delivery.

Ordering Number: L30960-N6901-A100

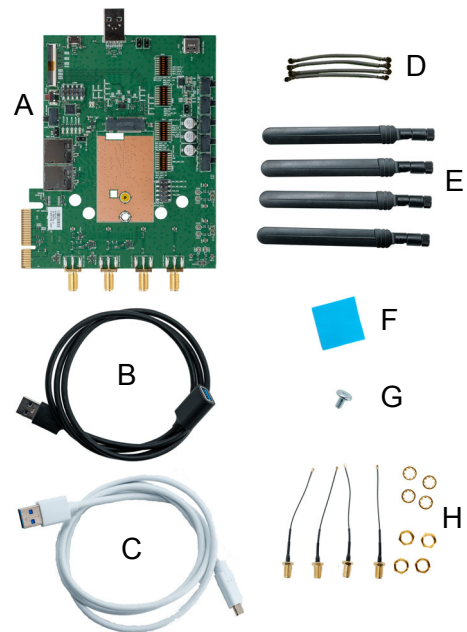

Figure 4: 5G Modem Card Adapter Board Kit

3.1.2 Package content PCIe® M.2 Variant

The package content for the PCIe M.2 Variant contains all parts delivered with the USB Variant and additional

- 1 FFC Cable (Figure 5 A)
- 1 M.2 Interface Board (Figure 5 B)

The 5G Modem Card Adapter Board is configured to use the PCIe M.2 Interface.

Ordering Number: L30960-N6902-A100

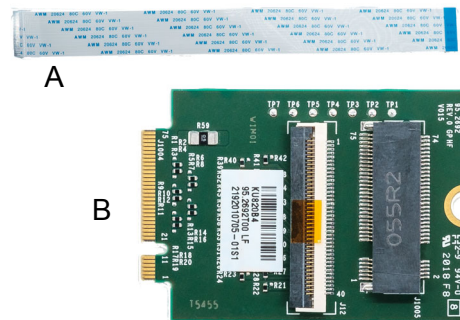

Figure 5: Additional Parts of 5G Modem Card Adapter Board Kit PCIe Variant

3.2 5G Modem Card Adapter Board Description

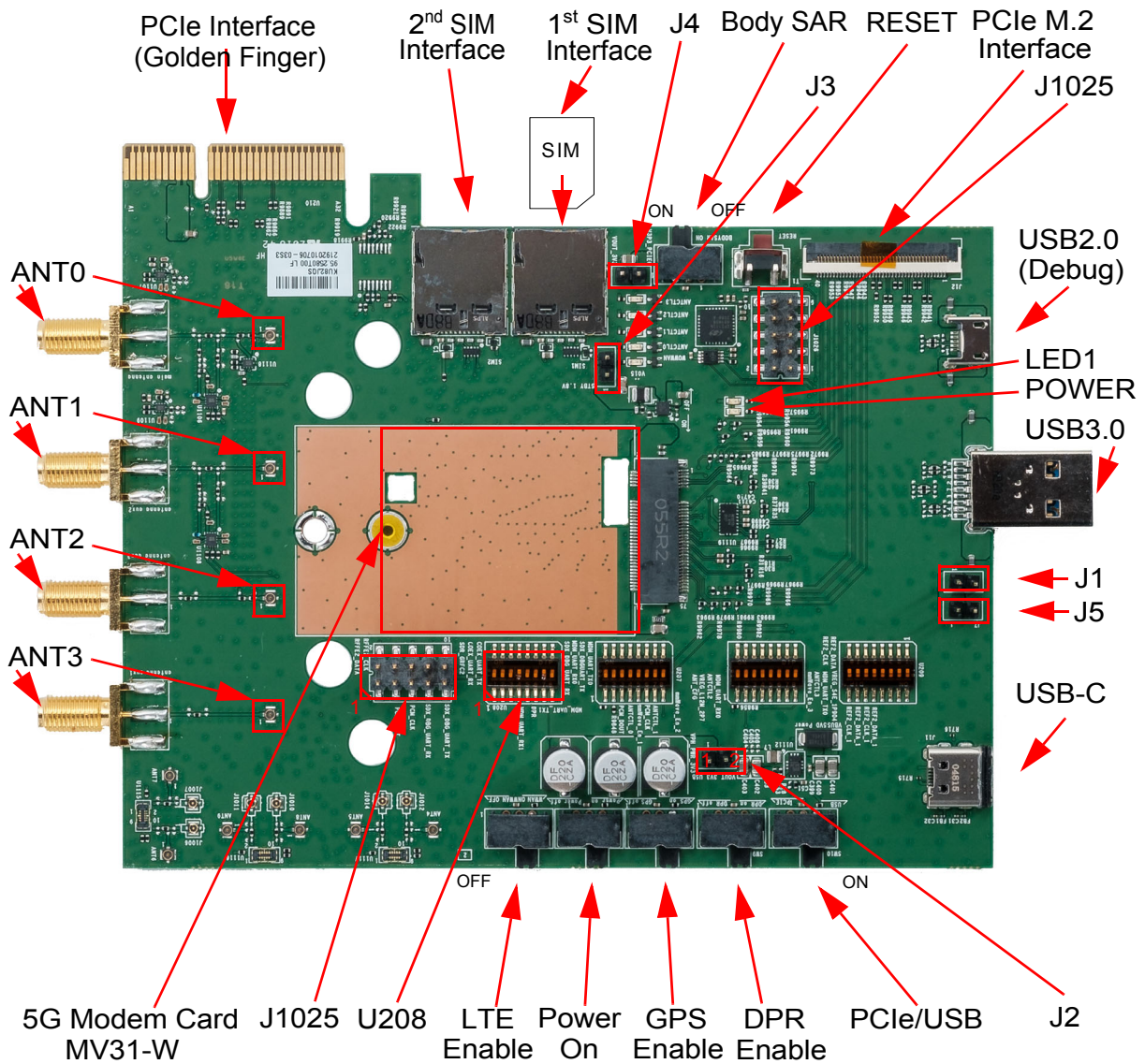

Figure 6: LTE Modem Card Adapter Board Jumper and Connectors

3.2 5G Modem Card Adapter Board Description

The 5G Modem Card Adapter Board supports different interfaces depending on the version you have ordered. Figure 7 gives an overview of the digital interface part.

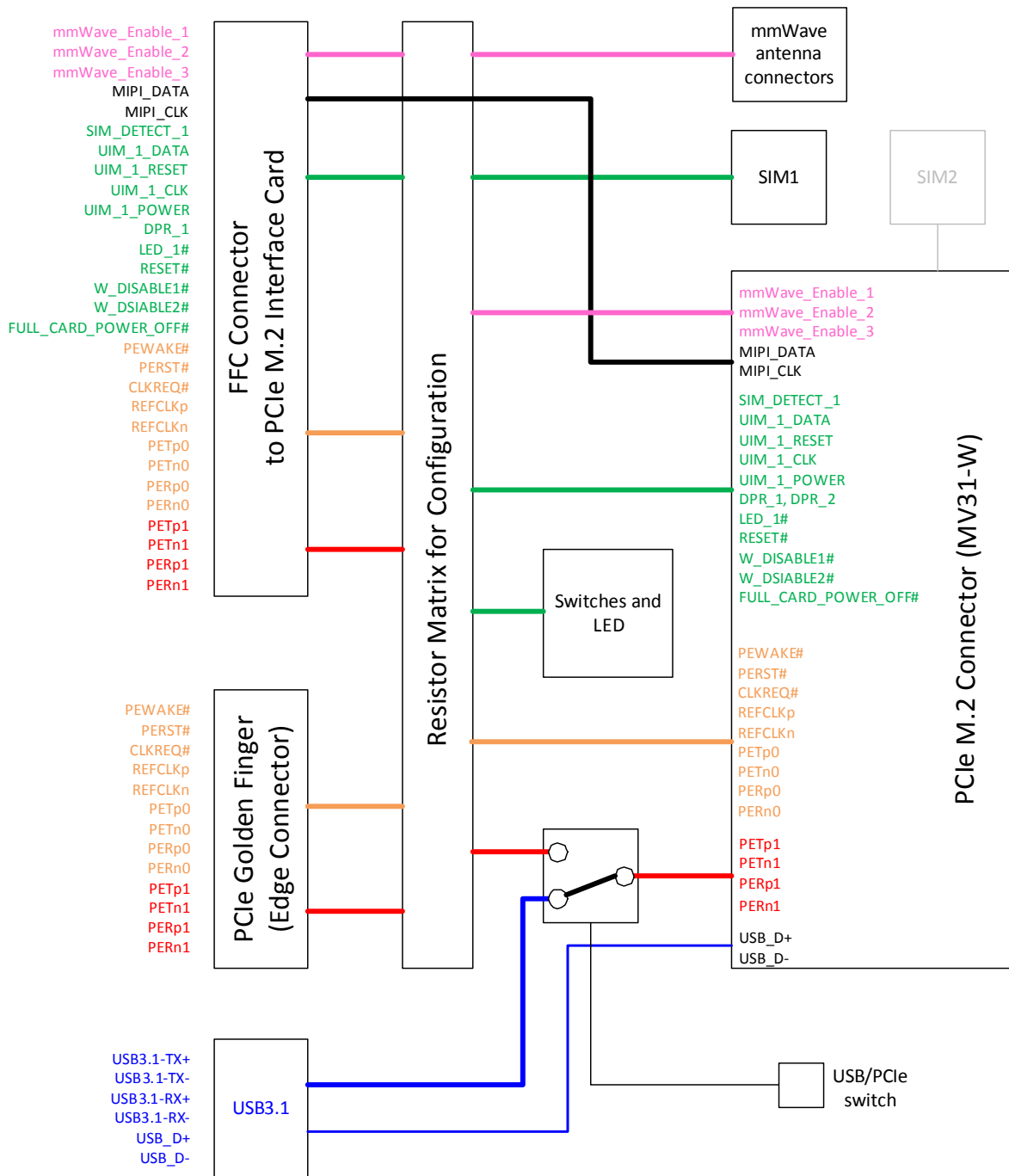

Figure 7: Block Diagram of the 5G Modem Card Adapter Board (digital interfaces)

The variants of the 5G Modem Adapter Board differ only in the resistor matrix.

3.2.1 USB Variant

The USB Variant communicates to the Host via a USB3.1 interface.

Table 4: Available Controls USB Variant

	5G Modem Card Adapter Board	PCIe M.2 Interface
SIM 1 Interface	SIM 1	-
SIM 2 Interface	SIM 2	-
Reset Switch	no function	RESET# from Host
Power On Switch	X	
LTE Enable Switch	no function	W_DISABLE1# from Host
GPS Enable Switch	no function	W_DISABLE2# from Host
BODY SAR Switch	no function	DPR_1 from Host
DPR Switch	function only when U208 6 on	-
LED1	LED_1#	-
Power Supply	Jumper Setting see Table 10 row 1 or 2	-
PCIe Bus	-	X
PCIe/USB Switch	must be set to USB (on)	-

[Section 3.3](#) shows how to change the configuration of SIM 1 Interface and Controls/LED.

3.2.2 PCIe® M.2 Variant

The PCIe M.2 Variant communicates with the Host via a PCIe M.2 interface. Therefore the M.2 Interface Adapter must be connected via the FFC cable to the FFC connector of the 5G Modem Card Adapter Board.

Table 5: Available Controls PCIe M.2 Variant

	5G Modem Card Adapter Board	PCIe M.2 Interface
SIM 1 Interface	-	on Host device
SIM 2 Interface	SIM 2	-
Reset Switch	no function	RESET# from Host
Power On Switch	no function	FULL_CARD_POWER_OFF# from Host
LTE Enable Switch	no function	W_DISABLE1# from Host
GPS Enable Switch	no function	W_DISABLE2# from Host
BODY SAR Switch	no function	DPR_1 from Host
DPR Switch	function only when U208 6 on	-
LED#1	no function	LED_1# to Host
Power Supply	-	Jumper Setting see Table 10 row 3
PCIe Bus	-	X

3.3 Resistor Matrix Configuration

Table 5: Available Controls PCIe M.2 Variant

	5G Modem Card Adapter Board	PCIe M.2 Interface
PCIe/USB Switch	must be set to PCIe (off)	-

[Section 3.3](#) shows how to change the configuration of SIM 1 Interface and Controls/LED.

3.2.3 PCIe® Golden Finger (Edge Connector) Configuration

This Variant can't be ordered and must be done by the customer. [Table 7](#), [Table 8](#) and [Table 9](#) show which resistors must be soldered and which resistors must be removed to get this configuration in [Table 6](#).

Table 6: Available Controls PCIe Golden Finger Configuration

	5G Modem Card Adapter Board	PCIe Golden Finger (Edge Connector)
SIM 1 Interface	SIM 1	-
SIM 2 Interface	SIM 2	-
Reset Switch	X	-
Power On Switch	X	-
LTE Enable Switch	X	-
GPS Enable Switch	X	-
BODY SAR Switch	X	-
DPR Switch	function only when U208 6 on (see Section 3.5)	-
LED1	X	-
Power Supply	-	Jumper Setting see Table 10 row 3
PCIe Bus	-	X
PCIe/USB Switch	must be set to PCIe (off)	-

3.3 Resistor Matrix Configuration

The PCIe Signals can be routed by removing and adding resistors to FFC connector for PCIe M.2 interface or to PCIe Golden Finger (Edge Connector). [Table 7](#) shows the required configurations. Only one resistor in a row can be soldered, the other resistor must be removed. The USB variant and PCIe M.2 variant are delivered with the setting shown in [Table 7](#).

Table 7: PCIe Bus Configuration

	USB Variant	PCIe M.2 Variant	PCIe Golden Finger (Edge Connector)
PEWAKE#	R9919	R9919	R9918
CLKREQ#	R9921	R9921	R9920
PERST#	R9940	R9940	R9922

3.3 Resistor Matrix Configuration

Table 7: PCIe Bus Configuration

	USB Variant	PCIe M.2 Variant	PCIe Golden Finger (Edge Connector)
REFCLKp	R30	R30	R16
REFCLKn	R18	R18	R31
PERp0	R12	R12	R11
PERn0	R17	R17	R15
PETp0	R29	R29	R20
PETn0	R27	R27	R25
PERp1	R34	R34	R35
PERn1	R36	R36	R37
PETp1	R40	R40	R41
PETn1	R38	R38	R39

Figure 8 shows the position of the Resistors for the PCIe Bus Configuration.

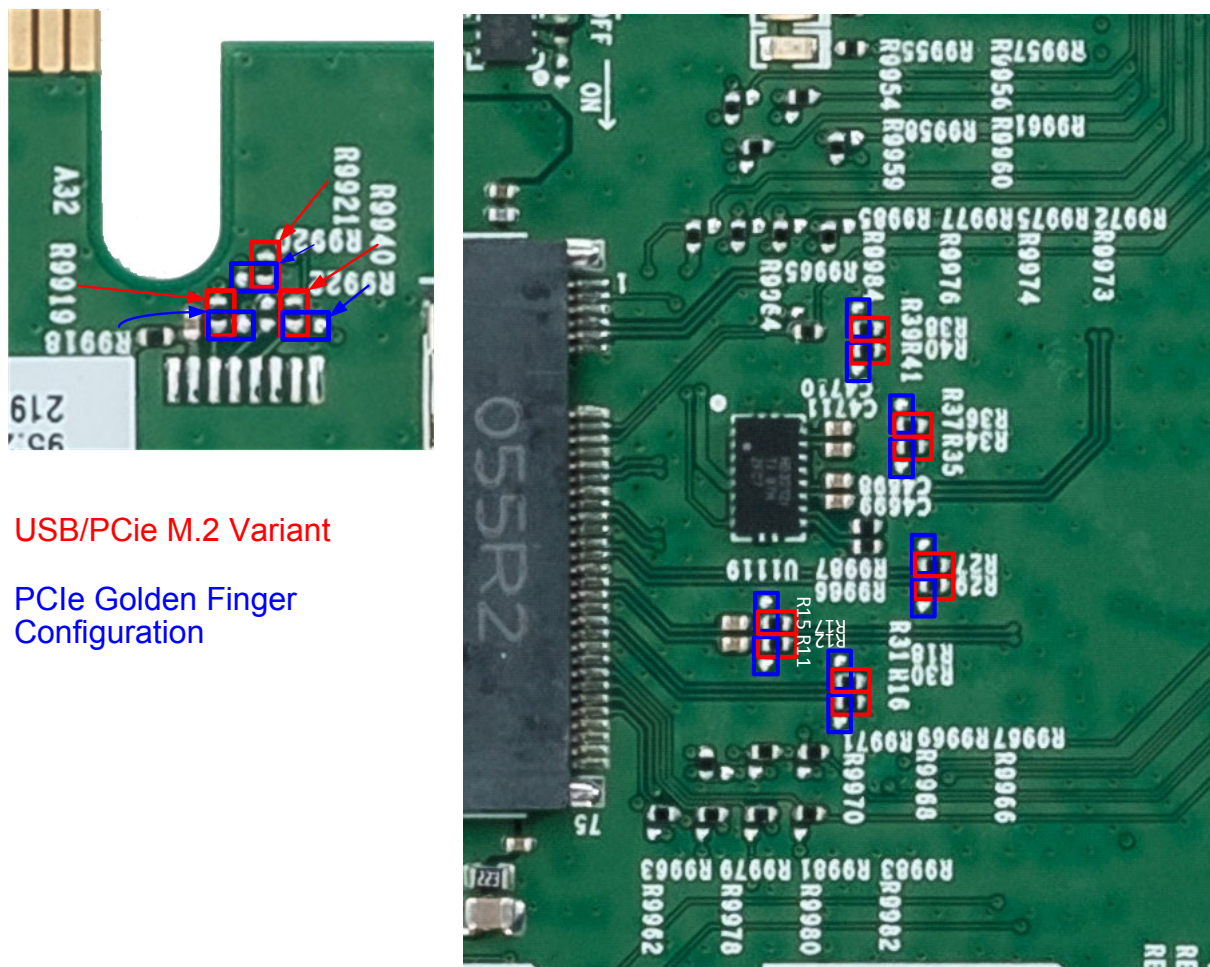

USB/PCIe M.2 Variant

PCIe Golden Finger Configuration

Figure 8: Position of the PCIe Bus Configuration Resistors

The SIM 1 Interface can be routed to the SIM 1 socket of the 5G Modem Card Adapter Board

3.3 Resistor Matrix Configuration

or to the PCIe M.2 Interface. Table 8 shows the possible configurations. Only one resistor in a row can be soldered, the other resistor must be removed.

Table 8: SIM 1 Configuration

	SIM 1 Socket on Adapter Board (delivered on USB Variant)	PCIe M.2 SIM Socket on Host (delivered on PCIe M.2 Variant)
SIM_DETECT_1	R9970	R9971
UIM_1_PWR	R9984	R9985
UIM_1_RESET	R9974	R9975
UIM_1_DATA	R9973	R9972
UIM_1_CLK	R9976	R9977

Figure 9 shows the position of the Resistors for the SIM 1 Interface Configuration.

USB Variant
PCIe M.2 Variant

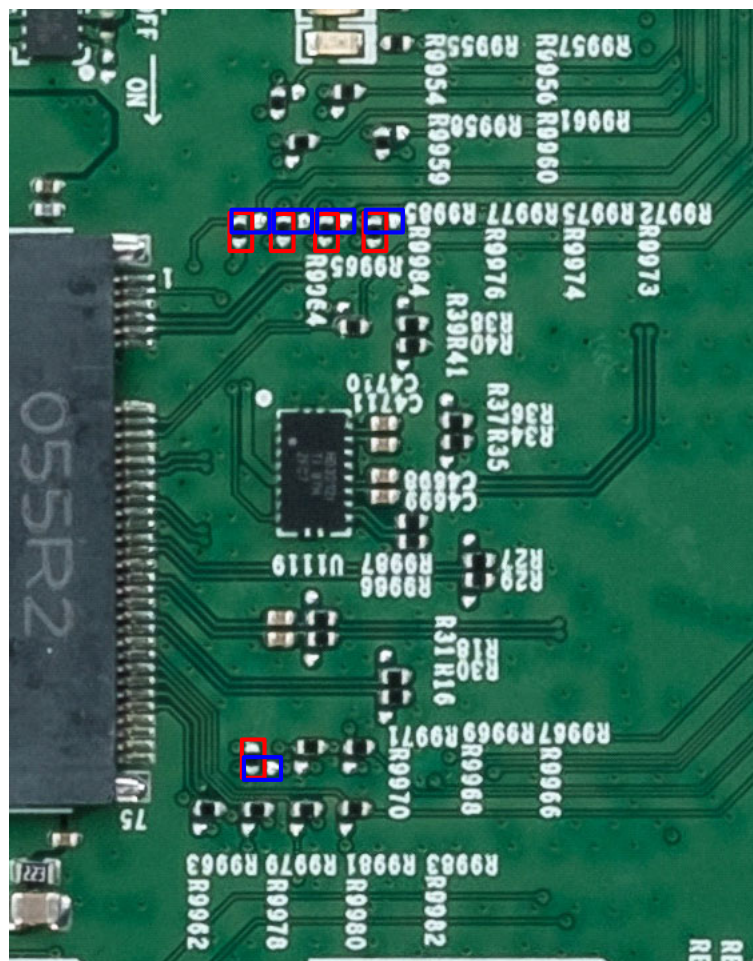

Figure 9: Position of the SIM 1 Interface Configuration Resistors

The signals in Table 9 can be controlled by switches on the 5G Modem Card Adapter Board or routed to the PCI M.2 Interface, where the Host takes over the control.

3.3 Resistor Matrix Configuration

Table 9: Switch/LED Configuration

MV31-W Interface	Adapter Board		PCIe M.2 Interface to Host	
Signal	Resistor	Switch/LED	Resistor	Signal
RESET#	R9962	RESET	R9963 ^{1,2}	RESET#
FULL_CARD_POWER_OFF#	R9954 ¹	Power On	R9955 ²	FULL_CARD_POWER_OFF#
W_DISABLE1#	R9956	LTE Enable	R9957 ^{1,2}	W_DISABLE1#
W_DISABLE2#	R9959	GPS Enable	R9958 ^{1,2}	W_DISABLE2#
DPR_1	R9964	Body SAR	R9965 ^{1,2}	DPR_1
LED1#	R9960 ¹	LED1	R9961 ²	LED#1

¹. Delivered on USB Variant
². Delivered on PCIe M.2 Variant

Figure 10 shows the position of the Resistors for the Control Signal Configuration.

- USB Variant only
- PCIe M.2 Variant only
- USB/PCIe M.2 Variant
- Alternate function

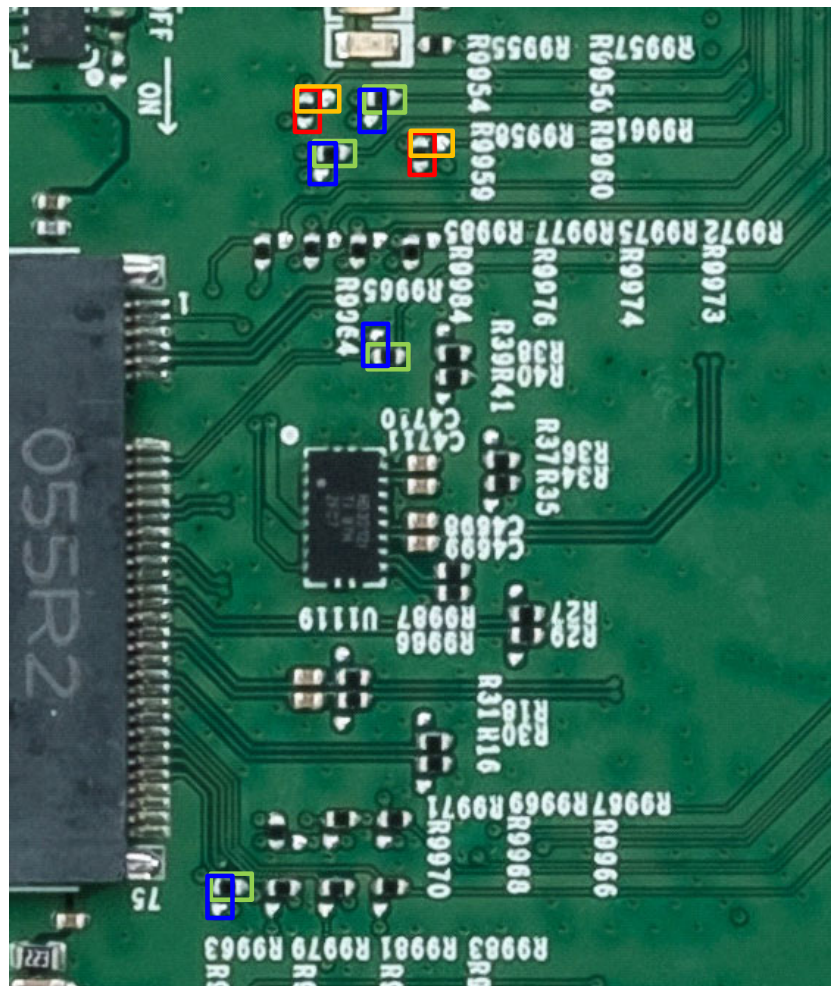

Figure 10: Position of the Control Signal Configuration Resistors

3.4 Power Supply Configuration

The 5G Modem Card Adapter Board can be powered over USB (USB 3.0 and USB-C), PCIe interface or by an external power supply. For configuration see [Table 10](#)

Table 10: Power Supply Configurations

		J1	J2	J3	J4	J5
1	Powered by USB3.0	mounted	mounted	mounted	removed	removed
2	Powered by USB3.0 and USB-C	mounted	mounted	mounted	removed	mounted
3	Powered by PCIe Interface (Golden Finger or PCIe M.2)	removed	mounted	mounted	mounted	removed
4	Powered external 3.3V	removed	inject PIN1	mounted	removed	removed

For the position of the Jumpers see [Figure 6](#).

3.5 Configuration Switches

The following [Table 11](#) show the recommended switch configuration.

Table 11: Switch Configuration

Switch Block	1	2	3	4	5	6	7	8
U206	OFF	OFF	OFF	OFF	OFF	OFF	OFF	OFF
U207	OFF	OFF	OFF	OFF	OFF	OFF	OFF	OFF
U208	OFF	OFF	OFF	ON	OFF	OFF	ON	OFF
U209	OFF	OFF	OFF	OFF	OFF	OFF	OFF	OFF

The [Table 12](#) shows the detailed function of the required switches.

Table 12: Switch Configuration in detail

Switch Block	Switch	Function when ON	Delivery State
U208	4	Enables Debug Interface (RX)	OFF
U208	6	Enables DPR Switch (signal DPR_2) ¹	OFF
U208	7	Enables Debug Interface (TX)	OFF

¹. Must be set to OFF, when Debug Interface is iused

For the position of the switches see [Figure 6](#).

3.6 Additional Connectors

J1025 (Table 13) and J1026 (Table 14) provide additional signals, which are not available at the standard interfaces. For the position of J1025 and J1026 see Figure 6.

Table 13: Signals at Jumper on J1025

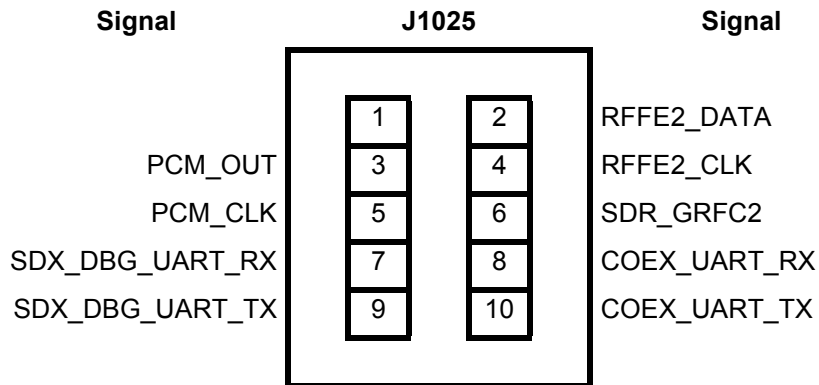
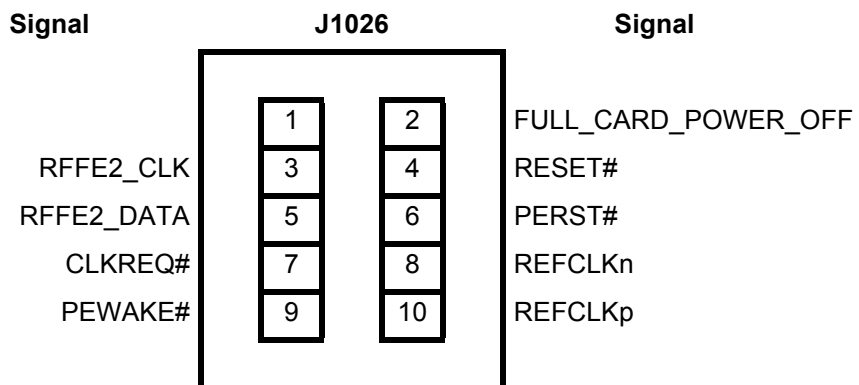

Table 14: Signals at Jumper on J1026



4 Appendix B mmWave Installation

4.1 Additional Equipment for mmWave

For using mmWave you need additional equipment:

- MV31-W mmWave variant
- 3 mmWave Antenna 525-5
- 3 FPC cables (optional, only required when special beam forming is required)
- 3 Coax cables with MLC03 connector and 2x JSC type connectors

Note: Module needs to be calibrated for beam forming. This depends on the antenna geometry (positioning of the antenna).

Table 15: mmWave Starter Kits ordering numbers

	mmWave Bands	Ordering Number
MMWAVE Starter Kit USB - 525-5	n257, n258, n260, n261	L30960-N6935-A100
MMWAVE Starter Kit PCIe - 525-5		L30960-N6936-A100

The mmWave Starter Kits contain corresponding accessories of the USB Starter Kit in [Section 3.1.1](#) or PCIe Starter Kit in [Section 3.1.2](#) plus cables and antennas needed for mmWave operation.

4.2 Connecting mmWave Antennas

Following steps has to be done:

1. Do the configuration of your 5G Modem Card Adapter Board as described in [Section 4.3](#) and [Section 4.4](#)
2. Connect coax cable with MLC03 connector and 2x JSC connectors to ANT4 of MV31-W and the black cable to J1007 and the white cable to J1006
3. Connect coax cable with MLC03 connector and 2x JSC connectors to ANT5 of MV31-W and the black cable to J1011 and the white cable to J1010
4. Connect coax cable with MLC03 connector and 2x JSC connectors to ANT6 of MV31-W and the black cable to J1014 and the white cable to J1012
5. Optional: connect FPC cables to U1115, U1116, U1117
6. Connect the mmWave antennas to the FPC cables or directly to U1115, U1116, U1117

[Figure 11](#) shows the location of the antenna connectors on MV31-W and [Figure 12](#) show the location of the mmWave antenna connectors on the 5G Modem Card Adapter Board.

4.2 Connecting mmWave Antennas



Figure 11: Antenna connectors on MV31-W mmWave Variant

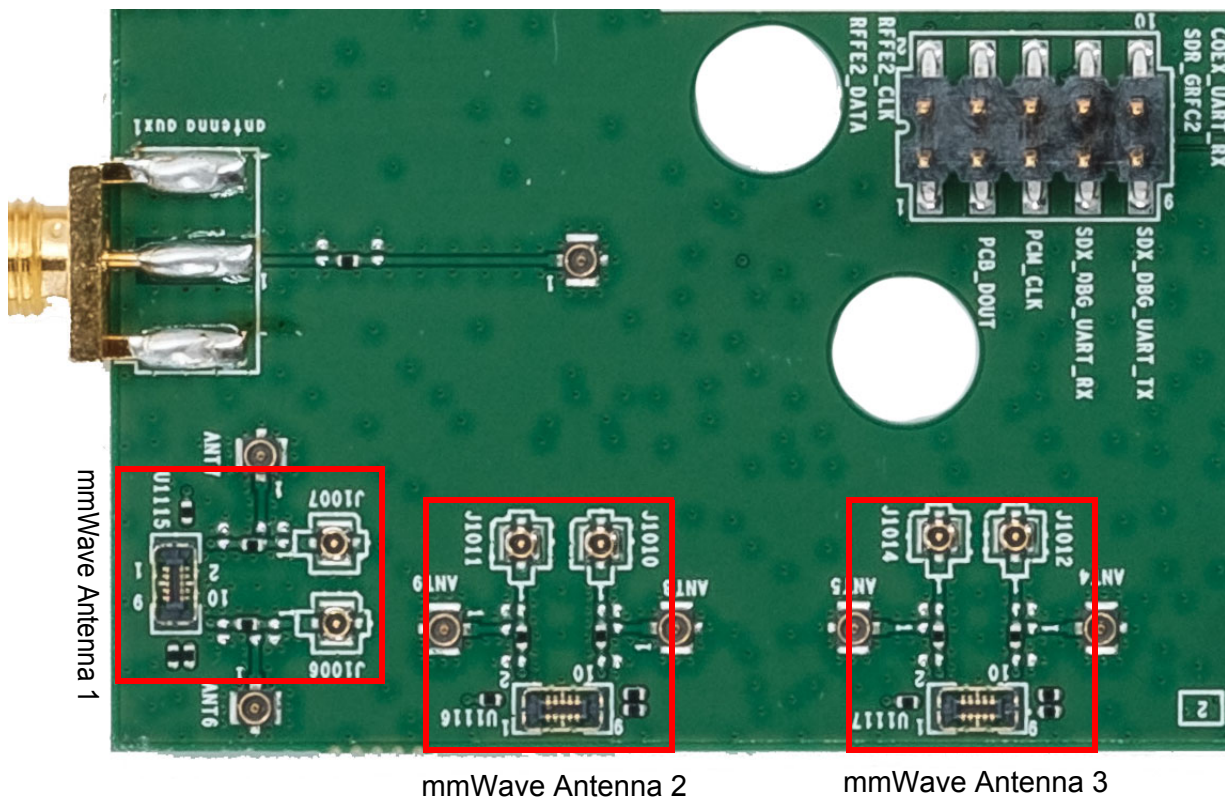

Figure 12: Location of the mmWave antenna connectors

4.2 Connecting mmWave Antennas

Figure 13 shows the mmWave antenna setup with out FPC cables.

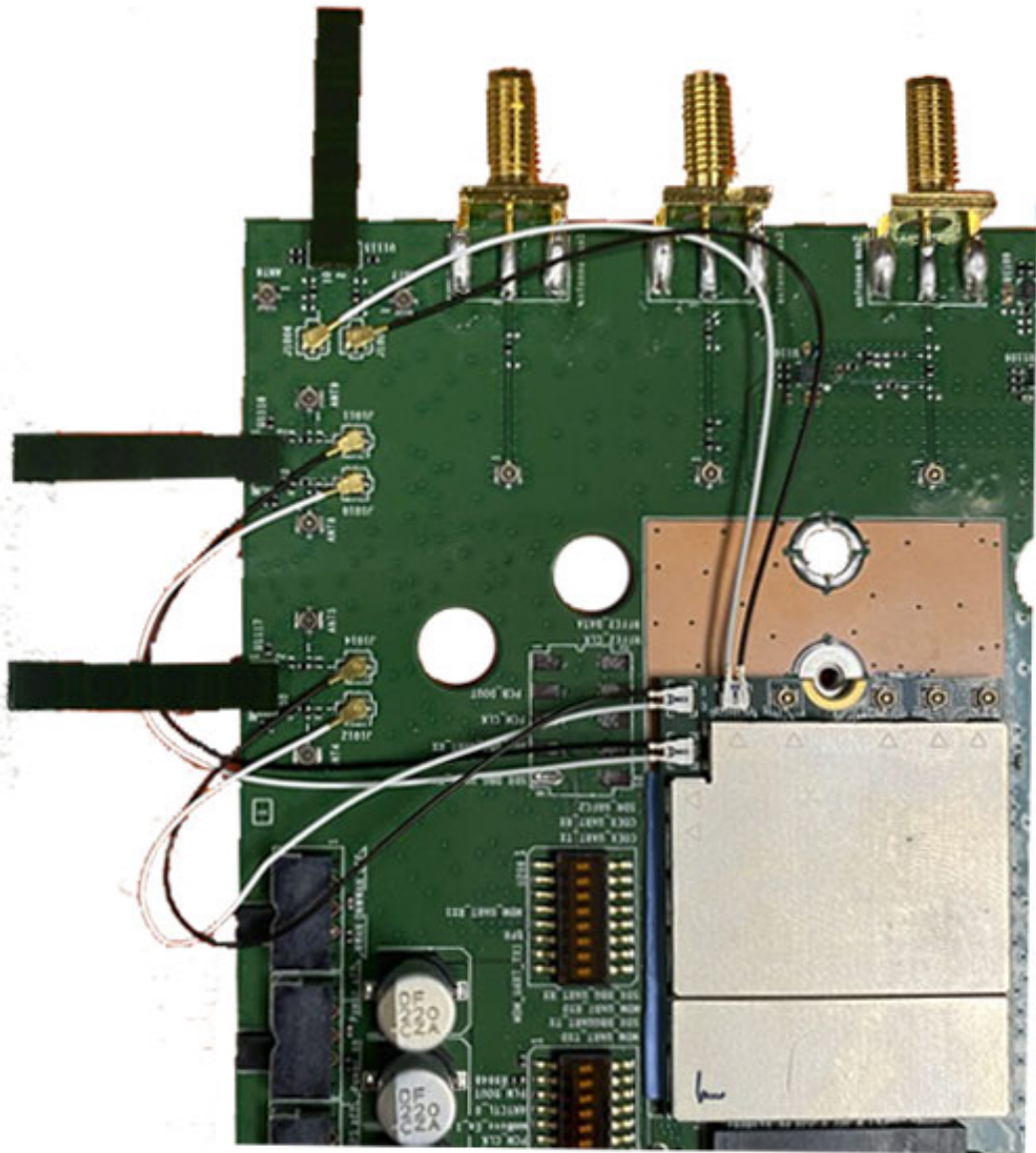

Figure 13: mmWave Antenna setup

4.3 Resistor Matrix Configuration mmWave

The signals in Table 16 can control mmWave Antenna connected to 5G Modem Card Adapter Board or routed to the PCI M.2 Interface, when the mmWave Antenna are implemented inside the Host.

Table 16: mmWave Control Signal Configuration

MV31-W Interface	Adapter Board		PCIe M.2 Interface to Host	
Signal	Resistor	Antenna connector LED	Resistor	Signal
mmWave_Enable_1	R9982	U1115 ANTCTL0	R9983 ¹	mmWave_Enable_1
mmWave_Enable_2	R9980	U1116 ANTCTL1	R9981 ¹	mmWave_Enable_2
mmWave_Enable_3	R9978	U1117 ANTCTL2	R9979 ¹	mmWave_Enable_3
mmWave_1P85		U1115/U1116/U1117 ANTCTRL3	not available	

¹: Configuration delivered

Figure 14 shows the position of the Resistors for the mmWave Enable Configuration.

USB/PCIe M.2 Variant
mmWave on Starter Kit

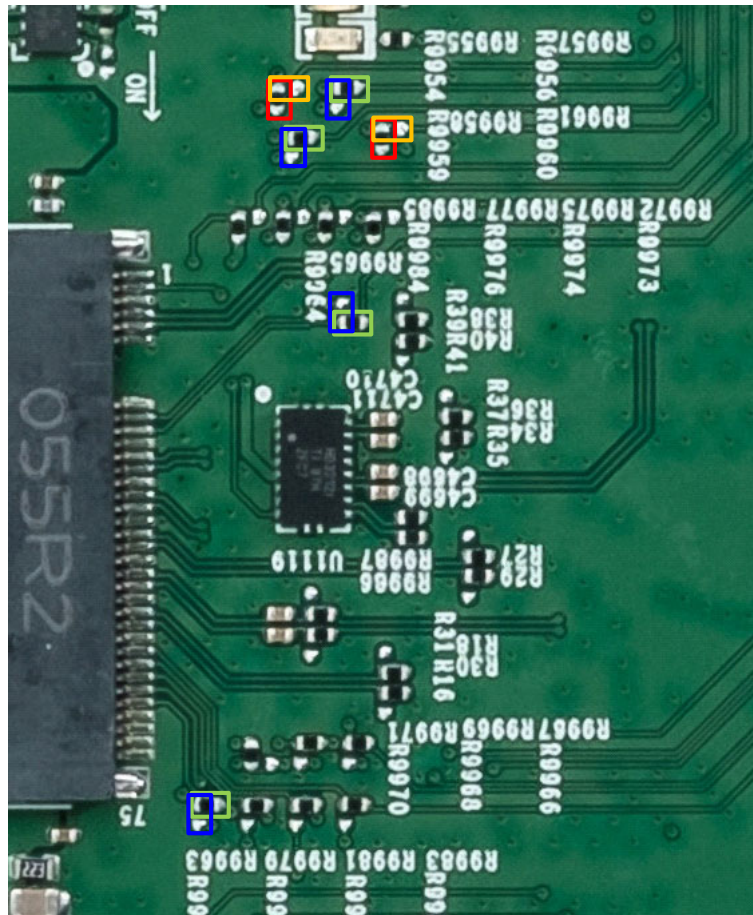

Figure 14: Position of the mmWave Enable Configuration Resistors

4.4 Configuration Switches mmWave

The following [Table 17](#) show the recommended switch configuration for using mmWave antenna connected to the Starter Kit.

Table 17: Switch Configuration for mmWave

Switch Block	1	2	3	4	5	6	7	8
U206	OFF	OFF	ON	OFF	ON	ON	OFF	ON
U207	OFF	OFF	OFF	ON	ON	OFF	ON	ON
U208	see Table 11							
U209								

The [Table 18](#) shows the detailed function of the required switches.

Table 18: Switch Configuration in detail for mmWave

Switch Block	Switch	Function when ON	Delivery State
U206	3	Enable LED ANTCTL2	OFF
U206	5	Enable mmWave_Enable_3 to U1117	OFF
U206	6	Enable LED ANTCTL3	OFF
U206	8	Enable mmWave_1P85 to U1115/U1116/U1117	OFF
U207	4	Enable LED ANTCTL0	OFF
U207	5	Enable mmWave_Enable_2 to U1115	OFF
U207	7	Enable LED ANTCTL1	OFF
U207	8	Enable mmWave_Enable_1 to U1116	OFF

For the position of the switches see [Figure 6](#).

4.5 mmWave Antenna Connector

The mmWave Antenne Q525 can be connected directly or via FPC cable to the mmWave connectors U1115, U1116 and U1117. Table 19 shows the signals on these connectors.

Table 19: Signals at mmWave Antenna Connectors

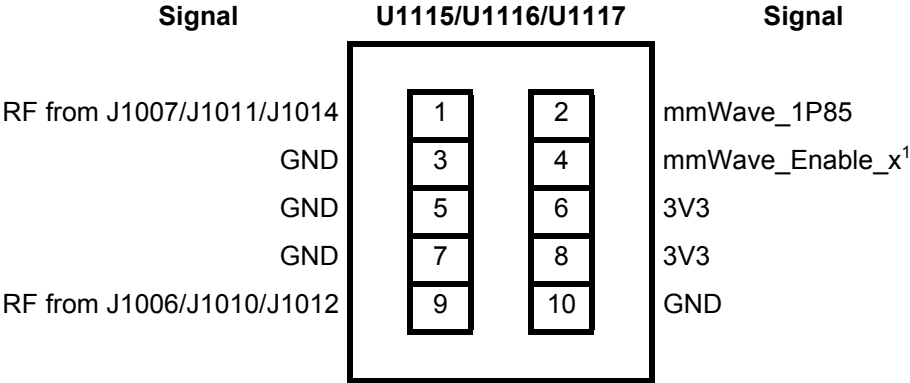

¹. x = 1 for U1115, 2 for U1116 or 3 for U1117



THALES DIS AIS Deutschland GmbH
Werinherstrasse 81
81541 Munich
Germany

THALES